

CATALOG A9



SEALING RINGS
RETAINING RINGS

This catalog "A9" was generated with great diligence based on the previous Fey laminar ring catalogs (A1 - A8) and all the information was checked for accuracy. However, we do not accept any liability for erroneous or incomplete information.

We are certified in accordance with:

DIN EN ISO 9001:2000

ISO/TS 16949:2002

ISO 14001:2004

We reserve the right to make changes due to technical developments.

Fey Lamellenringe Vertriebs GmbH
Einödstraße 18
A-2511 Pfaffstätten
Austria

Tel:+43(0)2252/88640

Fax:+43(0)2252/886402

E-Mail: office@feylamellenringe.com

Homepage: www.feylamellenringe.com

© Copyright by Fey Lamellenringe GmbH & Co. KG, 2007

All rights reserved.

Reprinting including excerpts or foreign languages is not permitted without our written approval.

The terms "Fey" and/or "Fey Lamellenringe" are copyrighted.

Those who have followed the development of Fey laminar rings since 1946 will remember that laminar rings were first produced in Germany in a single wound version. The "FK2 AS" was used to equip previously used pistons in internal combustion engines to re-establish the sealing or the compression in oval and "worn out" cylinders. These laminar rings were made from spring band steel or flat wire, including stainless steel and high-temperature alloys.

This first application of the Fey rings was successful for many years, however, it could not secure the economic future of Fey.

A significant condition for the further development of the Fey laminar ring sealings was the development of a cost effective manufacturing process, so that the rings could be manufactured individually in an oval format through thermal treatment, becoming round when installed in their working conditions as out-springing rings into bores or as in-springing rings on shafts by providing the highest possible gap sealing.

Using these arguments and the positive sealing effects of gap and labyrinth sealings, Fey was in a position to address the sealing problems of the industry and this resulted in increasing inquiries and requirements that led to a sealing program with a diameter range from 15 mm to 1,300 mm. In the meantime, Fey's manufacturing program consists of app. 16,800 ring types with different ring diameters, ring cross sections and different ring materials.

Successful users of Fey laminar rings include manufacturers of roller and plain bearings, exhaust pipes of internal combustion engines, axle bearings of rolling stock, continuous casting plants, transmission systems, power units and many more.

Our catalog is also available on a CD-ROM.



Please contact us!

Fey Lamellenringe
GmbH & Co. KG
Von der Bodenfräse zum Mars

Die **Fey** Bodenfräse und ihre Anwendung

1946
Die erste patentierte Erfindung der Firma Fey Lamellenringe: eine landwirtschaftliche Bodenfräse.

**DICHTUNGSRINGE
SICHERUNGSRINGE**

Fey
Lamellenringe

2003
Die Firma Fey Lamellenringe landet auf dem Mars. Im Greifarm „PLUTO“ des Landemoduls „Beagle 2“ vom europäischen Marsprojekt „Mars Express“ sind Fey Lamellenringe mit an Bord.

Fey laminar rings used as sealing elements for rotating and static sealing applications:

Fey laminar rings combine a low contact multiple labyrinth with very little gap width and are especially effective for grease sealings and for the exclusion of fluid media, dirt and dust entry as well as other contaminations. In addition to their outstanding sealing characteristics for rotating components, the low contact laminar rings with low friction produce a significant reduction of internal heat and wear, which qualifies these sealing elements for high speed applications and applications in temperature and/or friction sensitive installations.

For static sealing applications such as axial compensators at screwed exhaust manifold systems for internal combustion engines, exhaust gas recirculation systems and power units with operating temperatures of up to +700°C, Fey laminar rings will be manufactured from chrome nickel materials, which are spring and heat resistant in the sealing area even at high temperatures.

Design types include single wound (FK3) and double wound (FK6/FK5/FK5-HFL) laminar rings:

Fey laminar rings are offered as single wound laminar rings (AS and IS) with joint gap and as double wound laminar rings (ASD and ISD) without joint gap. The use of the different laminar ring geometries and the design of the installation technology depend on the operating conditions, the motion sequence of the components to be sealed and on the leakage requirements of the customer. In addition to single outspringing or single inspringing ring sets, Fey laminar rings can also be combined as a ring set within a groove: outspringing rings with inspringing rings and vice versa. The additional coverage of the groove base plays within the bore of the housing or at the groove base of the shaft optimize the labyrinth effect and therefore the sealing effect. However, we must point out that these combinations cannot be recommended for all sealing tasks.

One thing which must be avoided at all costs is that the laminar ring seal sets are moved axially by the movement of the groove, which may result from the axial play in the bearings. Depending on the frequency involved, friction would be generated between the ring and the groove flanks which may lead to premature wear of the rings and adjacent components.

Questionnaire (page 41):

This catalog cannot show all potential applications for the laminar rings. This is why we refer to the questionnaire. The answers may put us into the position to address your sealing issues and to propose appropriate recommendations.

Run and installation tests:

Run and installation tests under operating conditions must be performed in each case before standard production can begin to determine, whether the desired sealing effects for laminar sealing rings or the retaining effects for laminar retaining rings can be achieved. We recommend to contact our technical office for clarification.

Laminar piston rings

for pistons of internal combustion engines, compressors, pneumatic and hydraulic equipment, shock absorbers, etc.



Laminar piston rings

for pistons of freeform and drop forging machine, hydraulic controls and presses



Single laminar sealing rings

Single wound laminar rings for the sealing of grease lubricated roller and plain bearings.



Single and/or double laminar sealing rings

Single and/or double laminar sealing rings are used to seal compensators at exhaust pipes for internal combustion engines, turbochargers and turbines.

"FK5" rings are also used to seal bearing units for continuous casting plants.



Double laminar sealing rings

Double wound laminar rings for the sealing of grease lubricated roller and plain bearings for special requirements and also for high rotational speeds.



Laminar retaining rings

Single and double wound laminar retaining rings. DMS double laminar retaining rings with centrifugal force retainer for high shaft speeds.



Plastic laminar ring carrier seals

Plastic ring carriers with laminar sealing rings for the sealing of grease lubricated axle and machine bearings and conveyor belts.



Installation

Greasing

Questionnaire

Application examples

Application:

Laminar sealing rings "FK2" can be used for previously used and new internal combustion engines in connection with cast iron piston rings. Cast iron piston rings are not required for pistons of hydraulic and pneumatic equipment, compressors and shock absorbers. Please contact our technical office for information about ring dimensions, ring materials and groove geometries.

Piston sealings

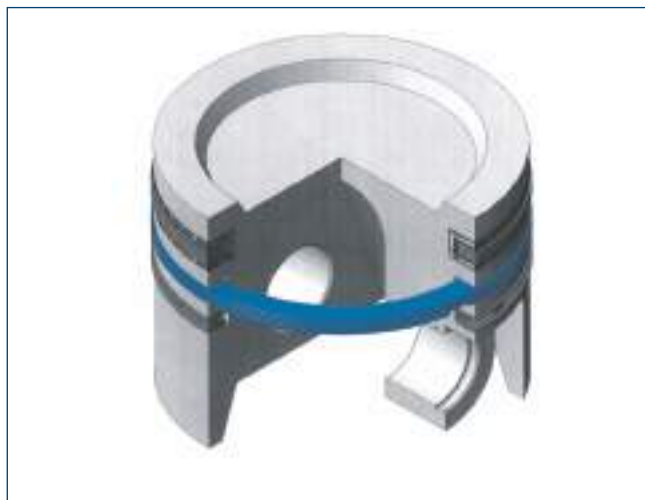

Application examples

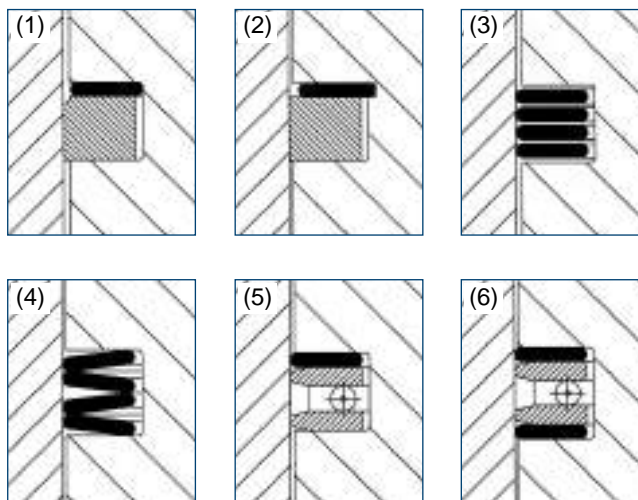

Hydraulic/pneumatic cylinder

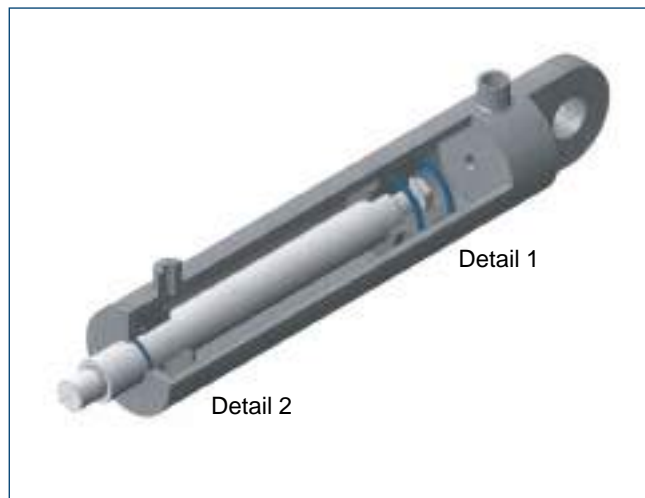

Hydraulic/pneumatic piston sealings



Scraper for hydraulic/pneumatic piston rod



Installation information:

See pages 38 and 39.

Order information:

The ring diameter information must match the housing or shaft diameter dimensions exactly for inquiries and/or orders for all ring types.

Run and installation tests:

Run and installation tests under operating conditions must be performed in each case before standard production of our laminar rings can begin to determine whether the desired sealing effects can be achieved.

Application:

Laminar sealing rings "FK4" for pistons of freeform and drop forging machines, presses and hydraulic controls. Please contact our technical office for information about ring dimensions, ring materials and groove geometries.

Ring materials

Steel type	Spring resistant up to	Hardness	Surface protection	Surface color
C75S - DIN 1.0605	max. +300°C	on request 1)	oiled	variable 2)
C60E - DIN 1.1221	max. +300°C	on request 1)	oiled	variable 2)
50CrV4- DIN 1.8159	max. +400°C	on request 1)	oiled	variable 2)

1) Variable depending on the thermal treatment type! Hardness values depending on ring cross section measured in Rockwell HRA or HRC.
 2) The surface color can vary depending on the thermal treatment type: bright, light brown or blackened.

Freeform/drop forging machine



Presses



Hydraulic control



Installation information:

See pages 38 and 39.

Order information:

The ring diameter information must match the housing or shaft diameter dimensions exactly for inquiries and/or orders for all ring types.

Run and installation tests:

Run and installation tests under operating conditions must be performed in each case before standard production of our laminar rings can begin to determine whether the desired sealing effects can be achieved.

Application "FK3 AS" Outside clamping single rings (3 rings = 1 set)

Single wound laminar sealing rings "FK3 AS" are used as a grease seal for roller and plain bearings and they protect, if greased, against dust entry and ambient moisture. The combined ring sets "FK3 ASK" (additional sealing of the groove base diameter) optimize the sealing effect due to the increased labyrinth effect.

The "FK3 AS" or "FK3 ASK" assemblies are normally preferred over the "FK3 IS" or "FK3 ISK" assemblies due to their easier installation into the grooves. Depending on the applications or the technical requirements, the ring carriers can be manufactured from steel, cast iron, light alloy or plastics.

Ring materials

Steel type	Spring resistant up to	Hardness	Surface protection	Surface color
C75S - DIN 1.0605	max. +300°C	on request ¹⁾	oiled	variable ²⁾
C60E - DIN 1.1221	max. +300°C	on request ¹⁾	oiled	variable ²⁾
50CrV4- DIN 1.8159	max. +400°C	on request ¹⁾	oiled	variable ²⁾
CrNi - DIN 1.4310	max. +450°C	on request ¹⁾	bright and dry	variable ²⁾

¹⁾ Variable depending on the thermal treatment type! Hardness values depending on ring cross section measured in Rockwell HRA or HRC.
²⁾ The surface color can vary depending on the thermal treatment type: bright, light brown or blackened.

Permissible circumferential speed (in m/s)

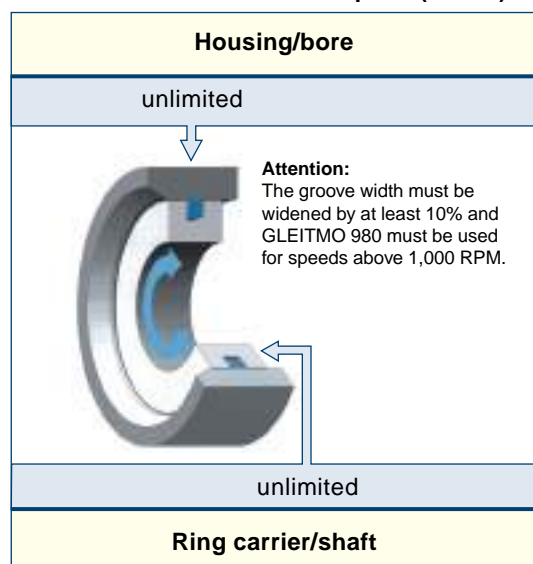

Axial and/or radial play ³⁾

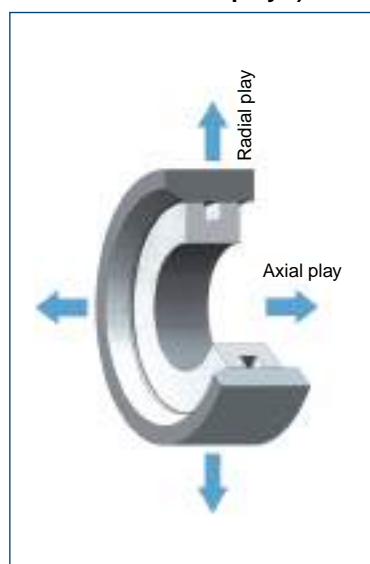

FK3 AS ring set ⁴⁾



Axial and/or radial play ³⁾:

The groove width "A" must be widened by twice the play if play occurs in the area of the rings. The groove base diameter "D₂" must be reduced by the radial play if radial play occurs. Damage to the rings and the surrounding components occurs if this is not adhered to. It is recommended to use the full groove width tolerances, especially in the case of thermal expansion.

Installation information:

See pages 38 and 39.

Order information ⁴⁾:

The ring diameter information must match the housing or bore diameter dimensions "D₁" for all inquiries and/or orders. The rings can be ordered individually or in sets (1 set = 3 AS rings).

Run and installation tests:

Run and installation tests under operating conditions must be performed in each case before standard production of our laminar rings can begin to determine whether the desired sealing effects can be achieved.

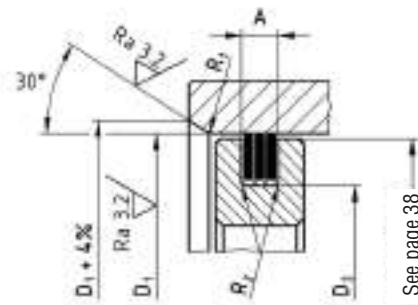
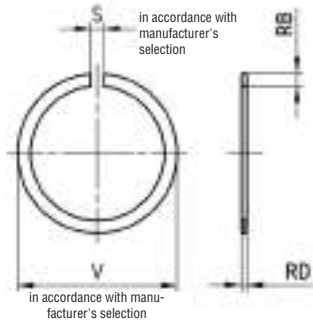

Nominal dimension		Ring dimensions				Groove dimensions					
Bore D ₁	Tolerance	RB	Tolerance	RD	Tolerance	D ₂ = D ₁ minus	Tolerance	A	Tolerance	R ₁	R ₂
15 - 24.9		1.0		0.65		- 2.6		2.2			
25 - 29.9		1.2		0.65		- 3.0		2.2			
30 - 35.9		1.5		0.65		- 3.6		2.2			
36 - 42.9		1.8		0.65		- 4.2		2.2			
43 - 48.9		2.2		0.72		- 5.0		2.4			
49 - 51.9		2.4		0.72		- 5.4		2.4			
52 - 59.9	H 6 H 7	2.6	+ 0.1 - 0.1	0.72	+ 0.04 - 0.02	- 5.8	+ 0 - 0.2	2.4	+ 0.1 - 0	min. 1	0.1
60 - 69.9		2.8		0.82		- 6.2		2.7			
70 - 74.9		3.1		0.82		- 6.8		2.7			
75 - 79.9		3.3		0.82		- 7.2		2.7			
80 - 89.9		3.5		0.82		- 7.6		2.7			
90 - 99.9		3.8		0.82		- 8.2		2.7			
100 - 104.9		4.1		0.82		- 8.8		2.7			
105 - 109.9		4.3		0.98		- 9.2		3.3			
110 - 119.9		4.6		0.98		- 9.8		3.3			
120 - 129.9	H 7 H 8	5.0	+ 0.1 - 0.2	0.98	+ 0.05 - 0.03	- 10.8	+ 0 - 0.25	3.3	+ 0.15 - 0	min. 2	0.2
130 - 149.9		5.5		0.98		- 11.8		3.3			
150 - 170.9		6.0		1.0		- 13.0		3.4			
150 - 170.9		*6.0		1.5		- 13.0		5.1			
171 - 199.9		7.0		1.0		- 15.0		3.4			
171 - 199.9		*7.0		1.5		- 15.0		5.1			
200 - 259.9	H 8 H 9	8.0	+ 0.15 - 0.3	1.2	+ 0.06 - 0.04	- 18.0	+ 0 - 0.3	4.1	+ 0.2 - 0	min. 3	0.3
200 - 259.9		*8.0		1.5		- 18.0		5.1			
260 - 319.9		9.0		1.5		- 20.0		5.1			
320 - 399.9		10.0		1.5		- 22.0		5.2			
400 - 439.9		11.0		1.5		- 24.0		5.2			
440 - 600.9		12.0		1.5		- 26.0		5.2			
440 - 600.9	H 9 H 10	*12.0	+ 0.2 - 0.4	2.5	+ 0.07 - 0.05	- 26.0	+ 0 - 0.4	8.3	+ 0.25 - 0	min. 4	0.4
601 - 699.9		14.0		2.5		- 32.0		8.3			
700 - 799.9		16.0		2.5		- 36.0		8.3			
800 - 899.9		18.0		2.5		- 40.0		8.3			
900 - 999.9		20.0		2.5		- 44.0		8.3			
1000 - 1300		22.0		2.5		- 48.0		8.4			

All dimensions in mm

*= reinforced ring design

Note: Please refer to the information on pages 2, 38, 39, 40 and 41 (questionnaire).

Please list exact bore or housing diameter "D₁ for all inquiries and orders!

Application "FK3 ASK" Outside clamping combined single rings (5 rings = 1 set)

Single wound laminar sealing rings "FK3 ASK" are used as a grease seal for roller and plain bearings and they protect, if greased, against dust entry and ambient moisture. Due to the increased labyrinth effect, the sealing effect is optimized by the additional sealing of the groove base diameter.

The "FK3 AS" or "FK3 ASK" assemblies are normally preferred over the "FK3 IS" or "FK3 ISK" assemblies due to their easier installation into the grooves. Depending on the applications or the technical requirements, the ring carriers can be manufactured from steel, cast iron, light alloy or plastics.

Ring materials

Steel type	Spring resistant up to	Hardness	Surface protection	Surface color
C75S - DIN 1.0605	max. +300°C	on request 1)	oiled	variable 2)
C60E - DIN 1.1221	max. +300°C	on request 1)	oiled	variable 2)
50CrV4- DIN 1.8159	max. +400°C	on request 1)	oiled	variable 2)
CrNi - DIN 1.4310	max. +450°C	on request 1)	bright and dry	variable 2)

1) Variable depending on the thermal treatment type! Hardness values depending on ring cross section measured in Rockwell HRA or HRC.
2) The surface color can vary depending on the thermal treatment type: bright, light brown or blackened.

Permissible circumferential speed (in m/s)

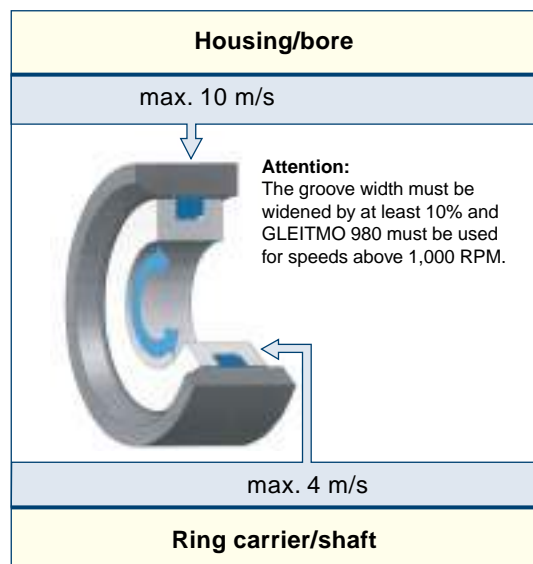

Axial and/or radial play 3)

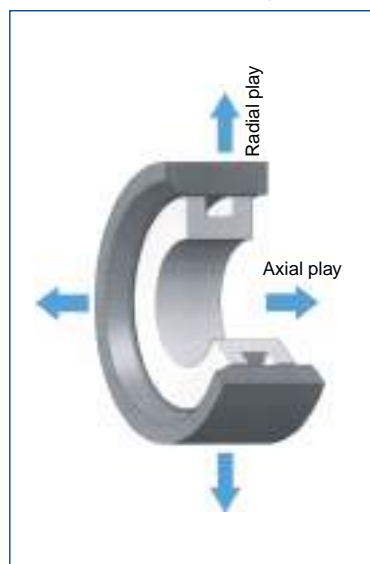

FK3 ASK ring set 4)



Axial and/or radial play 3):

The groove width "A" must be widened by twice the play if play occurs in the area of the rings. The groove base diameter "D₂" must be reduced by the radial play if radial play occurs. Damage to the rings and the surrounding components occurs if this is not adhered to. It is recommended to use the full groove width tolerances, especially in the case of thermal expansion.

Installation information:

See pages 38 and 39.

Order information 4):

The ring diameter information must match the housing or bore diameter dimensions "D₁" for all inquiries and/or orders. The rings can be ordered individually or in sets (1 set = 3 AS rings + 2 IS rings).

Run and installation tests:

Run and installation tests under operating conditions must be performed in each case before standard production of our laminar rings can begin to determine whether the desired sealing effects can be achieved.

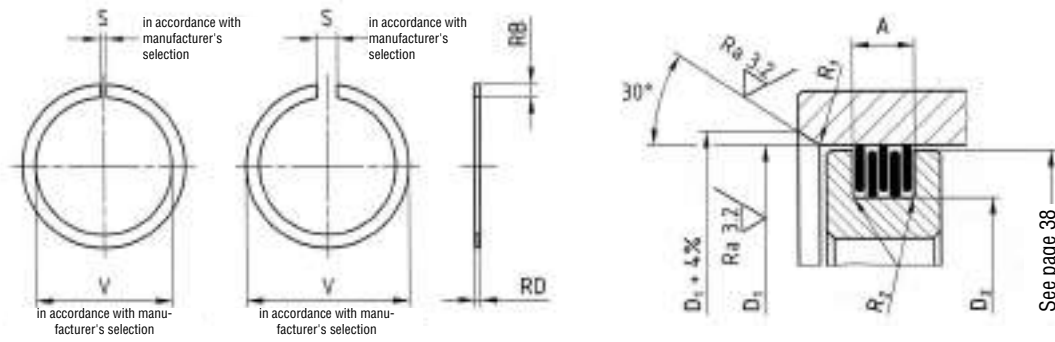

FK 3

ASK

Nominal dimension		Ring dimensions				Groove dimensions					
Bore D ₁	Tolerance	RB	Tolerance	RD	Tolerance	D ₂ = D ₁ minus	Tolerance	A	Tolerance	R ₁	R ₂
15 - 24.9		1.0		0.65		- 2.6		3.6			
25 - 29.9		1.2		0.65		- 3.0		3.6			
30 - 35.9		1.5		0.65		- 3.6		3.6			
36 - 42.9		1.8		0.65		- 4.2		3.6			
43 - 48.9		2.2		0.72		- 5.0		4.0			
49 - 51.9		2.4		0.72		- 5.4		4.0			
52 - 59.9	H 6	2.6	+ 0.1	0.72	+ 0.04	- 5.8	+ 0	4.0	+ 0.1	min.	
60 - 69.9	H 7	2.8	- 0.1	0.82	- 0.02	- 6.2	- 0.2	4.5	- 0	1	0.1
70 - 74.9		3.1		0.82		- 6.8		4.5			
75 - 79.9		3.3		0.82		- 7.2		4.5			
80 - 89.9		3.5		0.82		- 7.6		4.5			
90 - 99.9		3.8		0.82		- 8.2		4.5			
100 - 104.9		4.1		0.82		- 8.8		4.5			
105 - 109.9		4.3		0.98		- 9.2		5.5			
110 - 119.9	H 7	4.6	+ 0.1	0.98	+ 0.05	- 9.8	+ 0	5.5	+ 0.15	min.	
120 - 129.9	H 8	5.0	- 0.2	0.98	- 0.03	- 10.8	- 0.25	5.5	- 0	2	0.2
130 - 149.9		5.5		0.98		- 11.8		5.5			
150 - 170.9		6.0		1.0		- 13.0		5.6			
150 - 170.9		*6.0		1.5		- 13.0		8.2			
171 - 199.9		7.0		1.0		- 15.0		5.6			
171 - 199.9		*7.0		1.5		- 15.0		8.2			
200 - 259.9	H 8	8.0	+ 0.15	1.2	+ 0.06	- 18.0	+ 0	6.6	+ 0.2	min.	
200 - 259.9	H 9	*8.0	- 0.3	1.5	- 0.04	- 18.0	- 0.3	8.2	- 0	3	0.3
260 - 319.9		9.0		1.5		- 20.0		8.2			
320 - 399.9		10.0		1.5		- 22.0		8.3			
400 - 439.9		11.0		1.5		- 24.0		8.3			
440 - 600.9		12.0		1.5		- 26.0		8.3			
440 - 600.9		*12.0		2.5		- 26.0		13.5			
601 - 699.9	H 9	14.0	+ 0.2	2.5	+ 0.07	- 32.0	+ 0	13.5	+ 0.25	min.	
700 - 799.9	H 10	16.0	- 0.4	2.5	- 0.05	- 36.0	- 0.4	13.5	- 0	4	0.4
800 - 899.9		18.0		2.5		- 40.0		13.5			
900 - 999.9		20.0		2.5		- 44.0		13.5			
1000 - 1300		22.0		2.5		- 48.0		13.6			

All dimensions in mm

*= reinforced ring design

Note: Please refer to the information on pages 2, 38, 39, 40 and 41 (questionnaire).

Please list exact bore or housing diameter "D₁ for all inquiries and orders!

Application "FK3 IS" Inside clamping single rings (3 rings = 1 set)

Single wound laminar sealing rings "FK3 IS" are used as a grease seal for roller and plain bearings and they protect, if greased, against dust entry and ambient moisture. The combined ring sets "FK3 ISK" (additional sealing of the groove base diameter) optimize the sealing effect due to the increased labyrinth effect.

The "FK3 AS" or "FK3 ASK" assemblies are normally preferred over the "FK3 IS" or "FK3 ISK" assemblies due to their easier installation into the grooves. Depending on the applications or the technical requirements, the ring carriers can be manufactured from steel, cast iron, light alloy or plastics.

Ring materials

Steel type	Spring resistant up to	Hardness	Surface protection	Surface color
C75S - DIN 1.0605	max. +300°C	on request ¹⁾	oiled	variable ²⁾
C60E - DIN 1.1221	max. +300°C	on request ¹⁾	oiled	variable ²⁾
50CrV4- DIN 1.8159	max. +400°C	on request ¹⁾	oiled	variable ²⁾
CrNi - DIN 1.4310	max. +450°C	on request ¹⁾	bright and dry	variable ²⁾

¹⁾ Variable depending on the thermal treatment type! Hardness values depending on ring cross section measured in Rockwell HRA or HRC.
²⁾ The surface color can vary depending on the thermal treatment type: bright, light brown or blackened.

Permissible circumferential speed (in m/s)

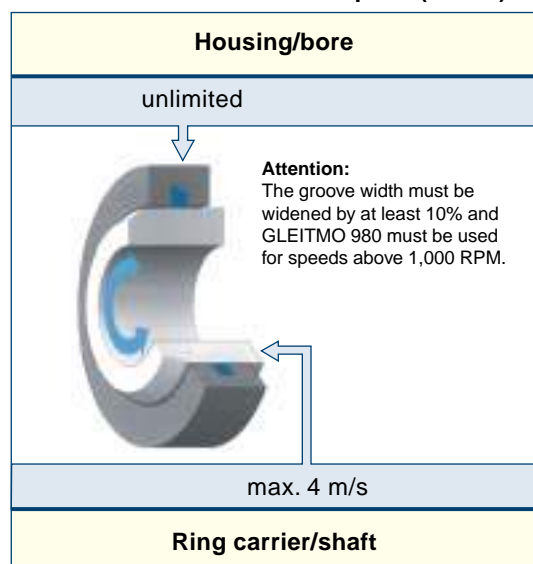

Axial and/or radial play ³⁾

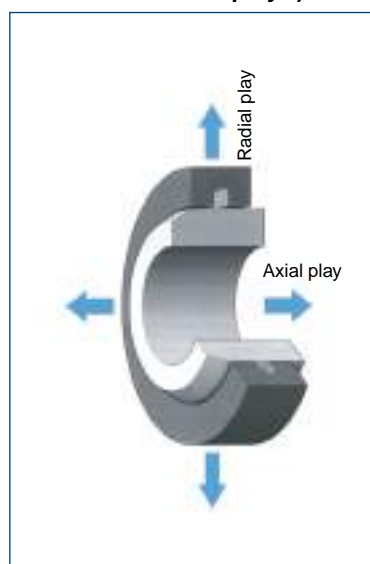

FK3 IS ring set ⁴⁾



Axial and/or radial play ³⁾:

The groove width "A" must be widened by twice the play if play occurs in the area of the rings. The groove base diameter "D₂" must be increased by the radial play if radial play occurs. Damage to the rings and the surrounding components occurs if this is not adhered to. It is recommended to use the full groove width tolerances, especially in the case of thermal expansion.

Installation information:

See pages 38 and 39.

Order information ⁴⁾:

The ring diameter information must match the shaft diameter dimensions "D₁" for all inquiries and/or orders. The rings can be ordered individually or in sets (1 set = 3 IS rings).

Run and installation tests:

Run and installation tests under operating conditions must be performed in each case before standard production of our laminar rings can begin to determine whether the desired sealing effects can be achieved.

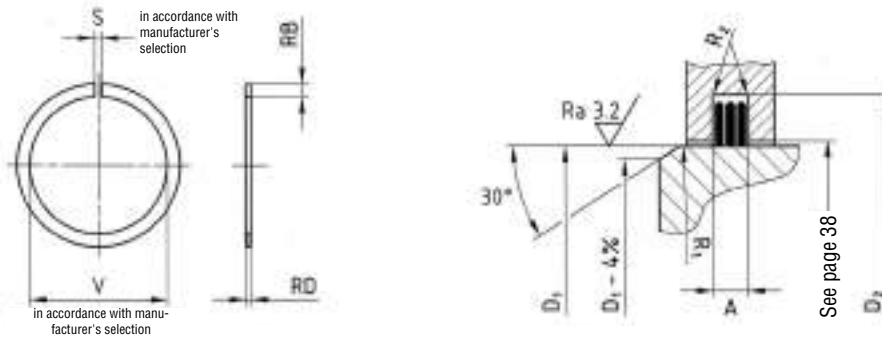

FK 3

IS

Nominal dimension		Ring dimensions				Groove dimensions												
Shaft D ₁	Tolerance	RB	Tolerance	RD	Tolerance	D ₂ = D ₁ plus	Tolerance	A	Tolerance	R ₁	R ₂							
15 - 24.9	h 6 h 7	1.0	+ 0.1 - 0.1	0.65	+ 0.04 - 0.02	+ 2.6	+ 0.2 - 0	2.2	+ 0.1 - 0	min. 1	0.1							
25 - 29.9		1.2		0.65		+ 3.0		2.2										
30 - 35.9		1.5		0.65		+ 3.6		2.2										
36 - 42.9		1.8		0.65		+ 4.2		2.2										
43 - 48.9		2.2		0.72		+ 5.0		2.4										
49 - 51.9		2.4		0.72		+ 5.4		2.4										
52 - 59.9		2.6		0.72		+ 5.8		2.4										
60 - 69.9		2.8		0.82		+ 6.2		2.7										
70 - 74.9		3.1		0.82		+ 6.8		2.7										
75 - 79.9		3.3		0.82		+ 7.2		2.7										
80 - 89.9		3.5		0.82		+ 7.6		2.7										
90 - 99.9		3.8		0.82		+ 8.2		2.7										
100 - 104.9	h 7 h 8	4.1	+ 0.1 - 0.2	0.82	+ 0.05 - 0.03	+ 8.8	+ 0.25 - 0	2.7	+ 0.15 - 0	min. 2	0.2							
105 - 109.9		4.3		0.98		+ 9.2		3.3										
110 - 119.9		4.6		0.98		+ 9.8		3.3										
120 - 129.9		5.0		0.98		+ 10.8		3.3										
130 - 149.9		5.5		0.98		+ 11.8		3.3										
150 - 170.9		6.0		1.0		+ 13.0		3.4										
150 - 170.9	h 8 h 9	*6.0	+ 0.15 - 0.3	1.5	+ 0.06 - 0.04	+ 13.0	+ 0.3 - 0	5.1	+ 0.2 - 0	min. 3	0.3							
171 - 199.9		7.0		1.0		+ 15.0		3.4										
171 - 199.9		*7.0		1.5		+ 15.0		5.1										
200 - 259.9		8.0		1.2		+ 18.0		4.1										
200 - 259.9		*8.0		1.5		+ 18.0		5.1										
260 - 319.9		9.0		1.5		+ 20.0		5.1										
320 - 399.9		10.0		1.5		+ 22.0		5.2										
400 - 439.9		11.0		1.5		+ 24.0		5.2										
440 - 600.9		12.0		1.5		+ 26.0		5.2										
440 - 600.9		h 9 h 10		*12.0		+ 0.2 - 0.4		2.5				+ 0.07 - 0.05	+ 26.0	+ 0.4 - 0	8.3	+ 0.25 - 0	min. 4	0.4
601 - 699.9				14.0				2.5					+ 32.0		8.3			
700 - 799.9				16.0				2.5					+ 36.0		8.3			
800 - 899.9	18.0		2.5	+ 40.0	8.3													
900 - 999.9	20.0	2.5	+ 44.0	8.3														
1000 - 1300	22.0	2.5	+ 48.0	8.4														

All dimensions in mm

*= reinforced ring design

Note: Please refer to the information on pages 2, 38, 39, 40 and 41 (questionnaire).

Please list exact shaft diameter "D₁" for all inquiries and orders!

Application "FK3 ISK" Inside clamping combined single rings (5 rings = 1 set)

Single wound laminar sealing rings "FK3 ISK" are used as a grease seal for roller and plain bearings and they protect, if greased, against dust entry and ambient moisture. Due to the increased labyrinth effect, the sealing effect is optimized by the additional sealing of the groove base diameter.

The "FK3 AS" or "FK3 ASK" assemblies are normally preferred over the "FK3 IS" or "FK3 ISK" assemblies due to their easier installation into the grooves. Depending on the applications or the technical requirements, the ring carriers can be manufactured from steel, cast iron, light alloy or plastics.

Ring materials

Steel type	Spring resistant up to	Hardness	Surface protection	Surface color
C75S - DIN 1.0605	max. +300°C	on request ¹⁾	oiled	variable ²⁾
C60E - DIN 1.1221	max. +300°C	on request ¹⁾	oiled	variable ²⁾
50CrV4- DIN 1.8159	max. +400°C	on request ¹⁾	oiled	variable ²⁾
CrNi - DIN 1.4310	max. +450°C	on request ¹⁾	bright and dry	variable ²⁾

¹⁾ Variable depending on the thermal treatment type! Hardness values depending on ring cross section measured in Rockwell HRA or HRC.
²⁾ The surface color can vary depending on the thermal treatment type: bright, light brown or blackened.

Permissible circumferential speed (in m/s)

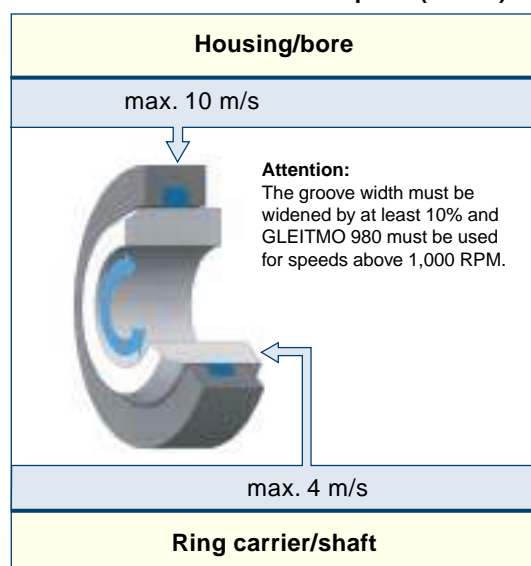

Axial and/or radial play ³⁾

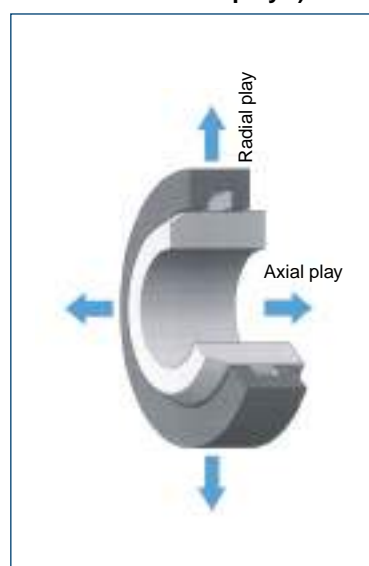

FK3 ISK ring set ⁴⁾



Axial and/or radial play ³⁾:

The groove width "A" must be widened by twice the play if play occurs in the area of the rings. The groove base diameter "D₂" must be increased by the radial play if radial play occurs. Damage to the rings and the surrounding components occurs if this is not adhered to. It is recommended to use the full groove width tolerances, especially in the case of thermal expansion.

Installation information:

See pages 38 and 39.

Order information ⁴⁾:

The ring diameter information must match shaft diameter dimensions "D₁" for all inquiries and/or orders. The rings can be ordered individually or in sets (1 set = 3 IS rings + 2 AS rings).

Run and installation tests:

Run and installation tests under operating conditions must be performed in each case before standard production of our laminar rings can begin to determine whether the desired sealing effects can be achieved.

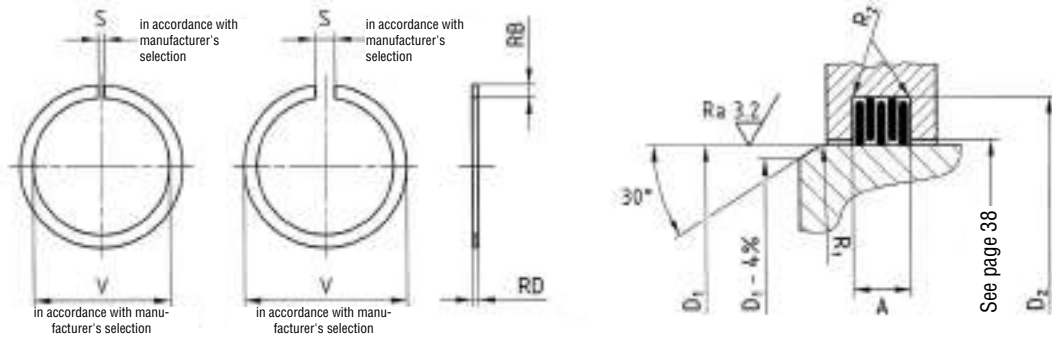

FK 3

ISK

Nominal dimension		Ring dimensions				Groove dimensions					
Shaft D ₁	Tolerance	RB	Tolerance	RD	Tolerance	D ₂ = D ₁ plus	Tolerance	A	Tolerance	R ₁	7
15 - 24.9		1.0		0.65		+ 2.6		3.6			
25 - 29.9		1.2		0.65		+ 3.0		3.6			
30 - 35.9		1.5		0.65		+ 3.6		3.6			
36 - 42.9		1.8		0.65		+ 4.2		3.6			
43 - 48.9		2.2		0.72		+ 5.0		4.0			
49 - 51.9		2.4		0.72		+ 5.4		4.0			
52 - 59.9	h 6	2.6	+ 0.1	0.72	+ 0.04	+ 5.8	+ 0.2	4.0	+ 0.1	min. 1	0.1
60 - 69.9	h 7	2.8	- 0.1	0.82	- 0.02	+ 6.2	- 0	4.5	- 0		
70 - 74.9		3.1		0.82		+ 6.8		4.5			
75 - 79.9		3.3		0.82		+ 7.2		4.5			
80 - 89.9		3.5		0.82		+ 7.6		4.5			
90 - 99.9		3.8		0.82		+ 8.2		4.5			
100 - 104.9		4.1		0.82		+ 8.8		4.5			
105 - 109.9		4.3		0.98		+ 9.2		5.5			
110 - 119.9	h 7	4.6	+ 0.1	0.98	+ 0.05	+ 9.8	+ 0.25	5.5	+ 0.15	min. 2	0.2
120 - 129.9	h 8	5.0	- 0.2	0.98	- 0.03	+ 10.8	- 0	5.5	- 0		
130 - 149.9		5.5		0.98		+ 11.8		5.5			
150 - 170.9		6.0		1.0		+ 13.0		5.6			
150 - 170.9		*6.0		1.5		+ 13.0		8.2			
171 - 199.9		7.0		1.0		+ 15.0		5.6			
171 - 199.9		*7.0		1.5		+ 15.0		8.2			
200 - 259.9	h 8	8.0	+ 0.15	1.2	+ 0.06	+ 18.0	+ 0.3	6.6	+ 0.2	min. 3	0.3
200 - 259.9	h 9	*8.0	- 0.3	1.5	- 0.04	+ 18.0	- 0	8.2	- 0		
260 - 319.9		9.0		1.5		+ 20.0		8.2			
320 - 399.9		10.0		1.5		+ 22.0		8.3			
400 - 439.9		11.0		1.5		+ 24.0		8.3			
440 - 600.9		12.0		1.5		+ 26.0		8.3			
440 - 600.9		*12.0		2.5		+ 26.0		13.5			
601 - 699.9	h 9	14.0	+ 0.2	2.5	+ 0.07	+ 32.0	+ 0.4	13.5	+ 0.25	min. 4	0.4
700 - 799.9	h 10	16.0	- 0.4	2.5	- 0.05	+ 36.0	- 0	13.5	- 0		
800 - 899.9		18.0		2.5		+ 40.0		13.5			
900 - 999.9		20.0		2.5		+ 44.0		13.5			
1000 - 1300		22.0		2.5		+ 48.0		13.6			

All dimensions in mm

*= reinforced ring design

Note: Please refer to the information on pages 2, 6, 38, 39, 40 and 41 (questionnaire).

Please list exact shaft diameter "D₁" for all inquiries and orders!

"FK5" application single and double laminar sealing rings

Single and double wound laminar sealing rings are used for sealing the roller and plain bearings on the segments rolls for continuous casting plants, industrial steam turbines, mobile and stationary power units. Basically everywhere the sealing system must meet severe requirements due to extreme operating conditions.

This includes corrosion or media resistance of the ring material, high operating temperatures and high contamination levels.

Ring materials

Steel type	Spring resistant up to	Hardness	Surface protection	Surface color
CrNi - DIN 1.4571	max. +500°C	on request ¹⁾	bright and dry	variable ²⁾
¹⁾ Variable depending on the thermal treatment type! Hardness values depending on ring cross section measured in Rockwell HRA or HRC. ²⁾ The surface color can vary depending on the thermal treatment type: bright, light brown or blackened.				

Continuous casting plant-diagram

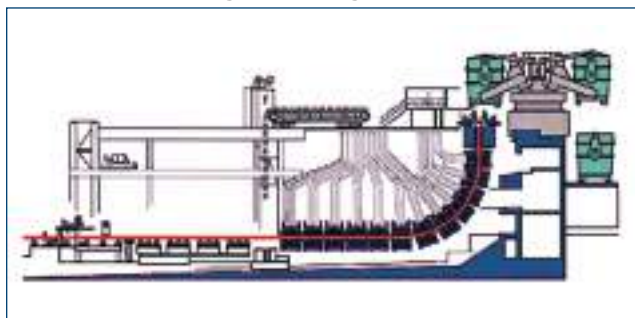

Floating bearing (example)

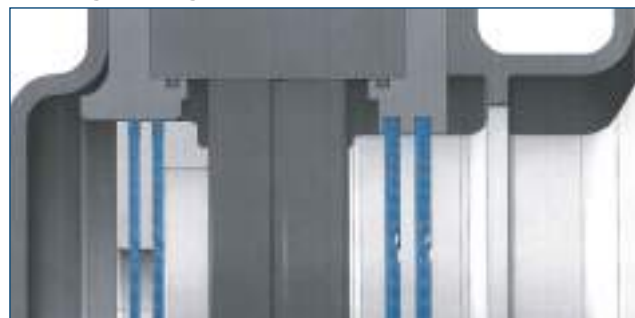

Drive roller (example)

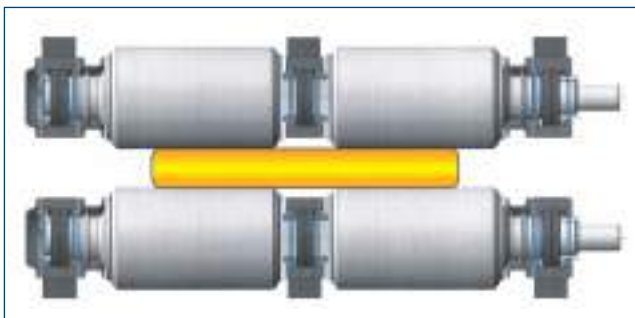

Support bearing (example)



Roller bed roller (example)

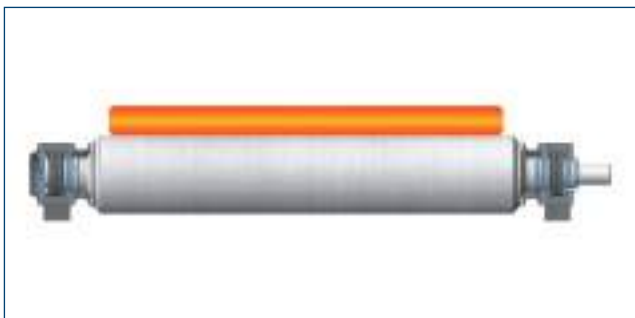

Fixed bearing (example)

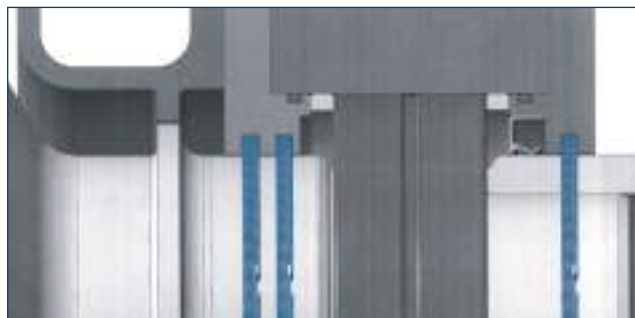

Installation information:

See pages 38 and 39.

Order information:

The ring diameter information must match the housing or shaft diameter dimensions "D₁" for all inquiries and/or orders. The rings can be ordered individually or in sets.

Run and installation tests:

Run and installation tests under operating conditions must be performed in each case before standard production of our laminar rings can begin to determine whether the desired sealing effects can be achieved.

For bore sealing

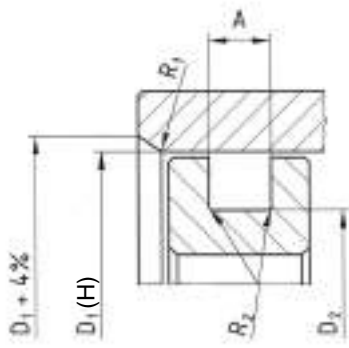

For shaft sealing

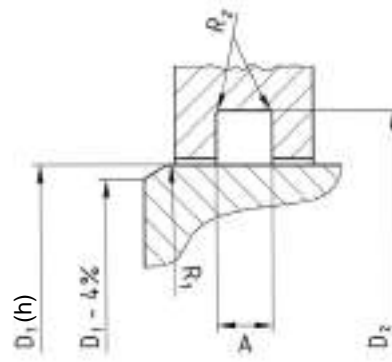

Nominal dimension		Ring dimensions				Groove dimensions					
Bore/shaft D ₁	Tolerance	RB	Tolerance	RD	Tolerance	D ₂ = D ₁ minus/plus	Tolerance	A	Tolerance	R ₁	R ₂
15 - 24.9	H/h 6 H/h 7	1.0	+ 0.1 - 0.1	1.3	+ 0.08 - 0.04						
25 - 29.9		1.2		1.3							
30 - 35.9		1.5		1.3							
36 - 42.9		1.8		1.3							
43 - 48.9		2.2		1.45							
49 - 51.9		2.4		1.45							
52 - 59.9		2.6		1.45							
60 - 69.9		2.8		1.65							
70 - 74.9		3.1		1.65							
75 - 79.9		3.3		1.65							
80 - 89.9	3.5	1.65									
90 - 99.9	3.8	1.65									
100 - 104.9	H/h 7 H/h 8	4.1	+ 0.1 - 0.2	1.65	+ 0.1 - 0.06						
105 - 109.9		4.3		1.96							
110 - 119.9		4.6		1.96							
120 - 129.9	H/h 8 H/h 9	5.0	+ 0.15 - 0.3	1.96	+ 0.12 - 0.08						
130 - 149.9		5.5		1.96							
150 - 170.9		6.0		2.0							
150 - 170.9	H/h 8 H/h 9	*6.0	+ 0.15 - 0.3	3.0	+ 0.12 - 0.08						
171 - 199.9		7.0		2.0							
171 - 199.9		*7.0		3.0							
200 - 259.9	H/h 8 H/h 9	8.0	+ 0.15 - 0.3	2.4	+ 0.12 - 0.08						
200 - 259.9		*8.0		3.0							
260 - 319.9		9.0		3.0							
320 - 399.9	H/h 8 H/h 9	10.0	+ 0.15 - 0.3	3.0	+ 0.12 - 0.08						
400 - 439.9		11.0		3.0							
440 - 600.9		12.0		3.0							
440 - 600.9	H/h 9 H/h 10	*12.0	+ 0.2 - 0.4	5.0	+ 0.14 - 0.1						
601 - 699.9		14.0		5.0							
700 - 799.9		16.0		5.0							
800 - 900.0	H/h 10	18.0	+ 0.2 - 0.4	5.0	+ 0.14 - 0.1						

Groove dimensions on request
Please contact our technical office!

↑ All dimensions in mm
 * = reinforced ring design
 Note: Please refer to the information on pages 2, 38, 39, 40 and 41 (questionnaire).
 Please list exact bore or shaft diameter "D₁" for all inquiries and orders!

FK 5-HFL

Single and double laminar sealing rings

for the sealing of axial compensators in exhaust pipes of internal combustion engines, manifold sheet metal pipe connections, exhaust gas recirculation systems and turbochargers







"FK5-HFL" application single and double laminar sealing rings

Single and double wound laminar sealing rings with the identification "FK5-HFL" are made from high-temperature chrome-nickel steels and are designed for the sealing for axial and radial compensators at exhaust pipes of internal combustion engines, exhaust gas recirculation systems, exhaust valves, turbochargers, mobile and stationary power units. Especially for applications that deal with high operating temperatures and high axial and radial movements due to thermal expansions.

Ring materials

Steel type	Spring resistant up to	Hardness	Surfaces-treatment	Surfaces-protection	Surfaces-color
CrNi - DIN 1.4571	max. +500°C	on request ¹⁾	Vibratory grinding	dry	variable ²⁾
CrNi - DIN 1.4980	max. +700°C	on request ¹⁾	Vibratory grinding	dry	variable ²⁾

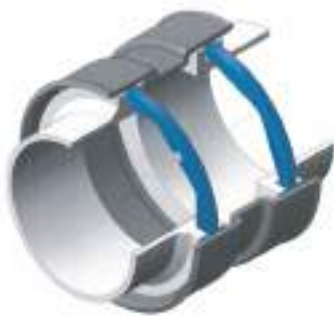
¹⁾ Variable depending on the thermal treatment type! Hardness values depending on ring cross section measured in Rockwell HRA or HRC.
²⁾ The surface color can vary depending on the thermal treatment type: bright, light brown or blackened.

Cast iron coupling examples		
Single side coupling	Double side coupling	90° arc coupling
		
Sheet metal coupling with centering expander examples		
Single side sheet metal pipe coupling	Double side sheet metal coupling	Angled sheet metal coupling
		

Expander dimensions on request

Installation information:

See pages 38 and 39.

Order information:

The ring diameter information must match housing diameter dimensions "D₁" for all inquiries and/or orders. The rings can be ordered individually or in sets.

Run and installation tests:

Run and installation tests under operating conditions must be performed in each case before standard production can begin to determine whether the desired sealing effects can be achieved.

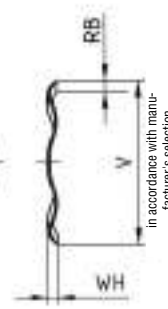
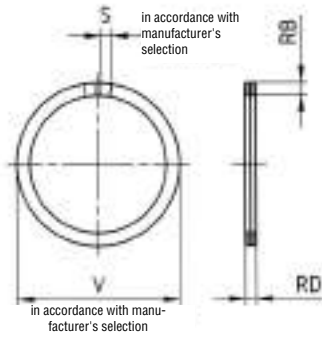

Wave spring FK9
Dimensions and diameters on request.
Please contact our technical office for these questions!

Nominal dimension		Ring dimensions				Groove dimensions					
Bore D ₁	Tolerance	RB	Tolerance	RD	Tolerance	NT	Tolerance	A	Tolerance	R ₁	R ₂
30 - 39.9	H 7	2.2	+ 0.1 - 0.1	1.45	+ 0.06 - 0.04	Groove dimensions on request Please contact our technical office!					
40 - 49.9		2.2		1.45							
50 - 59.9		2.6		1.45							
60 - 69.9		2.8		1.65							
70 - 79.9		3.3		1.65							
80 - 89.9		3.8	1.65								
90 - 104.9		4.1	1.65								
105 - 119.9		4.5	+ 0.1	1.95							
120 - 140		5.0	- 0.2	1.95							

FK 5

HFL

All dimensions in mm
Please contact our technical office for other dimensions.
Note: Please refer to the information on pages 2, 38, 39, 40 and 41 (questionnaire).
Please list exact bore diameter "D₁" for all inquiries and orders!

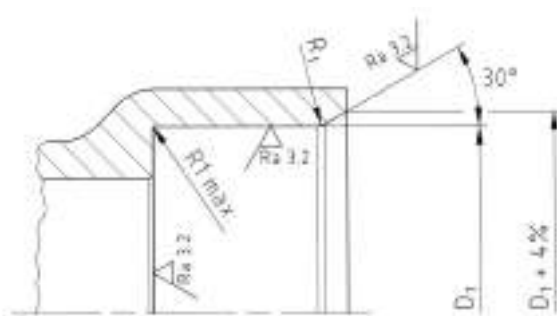

Bore/housing

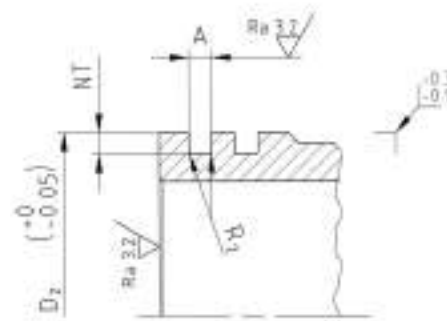

Ring carrier

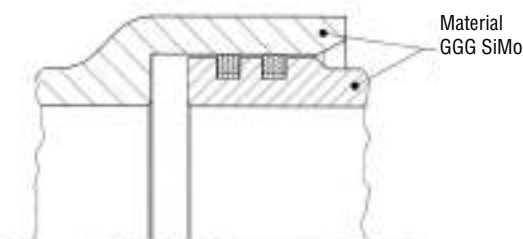

Installation situation

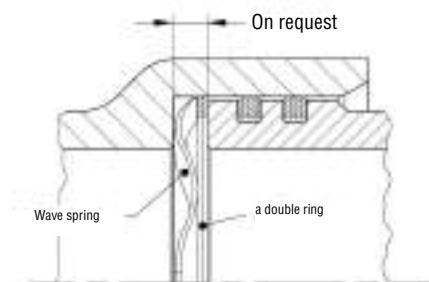

Installation situation with FK9 wave spring pre-sealing

Application "FK6 ASD" Outside clamping double rings (2 rings = 1 set)

In contrast to the single wound laminar sealing rings "FK 3", "FK6" laminar rings are double wound. They are used as grease seals for roller and plain bearings. They are also used as a protection seal in front of hermetically acting seal arrangements. The "FK 6" laminar rings must meet special sealing requirements against grease leakage and against dust, dirt and splash water ingress. "FK 6" laminar rings provide a uniform radial tension and, in contrast to the "FK 3" laminar rings, they have no axial joint gap. The combined ring sets "FK6 ASKD" (additional sealing of the groove base diameter) optimize the sealing effect due to the increased labyrinth effect.

The "FK6 ASD" or "FK6 ASKD" assemblies are normally preferred over the "FK6 ISD" or "FK6 ISKD" due to their easier ring installation into the grooves of the ring carriers. Depending on the applications or the technical requirements, the ring carriers can be manufactured from steel, cast iron, light alloy or plastics.

Ring materials

Steel type	Spring resistant up to	Hardness	Surface protection	Surface color
C75S - DIN 1.0605	max. +300°C	on request ¹⁾	oiled	variable ²⁾
C60E - DIN 1.1221	max. +300°C	on request ¹⁾	oiled	variable ²⁾
50CrV4- DIN 1.8159	max. +400°C	on request ¹⁾	oiled	variable ²⁾
CrNi - DIN 1.4310	max. +450°C	on request ¹⁾	bright and dry	variable ²⁾

¹⁾ Variable depending on the thermal treatment type! Hardness values depending on ring cross section measured in Rockwell HRA or HRC.

²⁾ The surface color can vary depending on the thermal treatment type: bright, light brown or blackened.

Permissible circumferential speed (in m/s)



Axial and/or radial play ³⁾

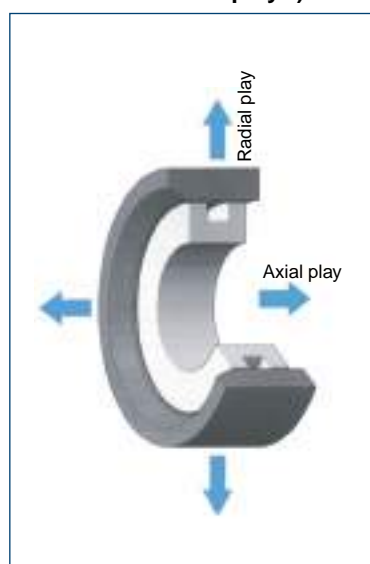

FK6 ASD ring set ⁴⁾



Axial and/or radial play ³⁾:

The groove width "A" must be widened by twice the play if play occurs in the area of the rings. The groove base diameter "D₂" must be reduced by the radial play if radial play occurs. Damage to the rings and the surrounding components occur if this is not adhered to. It is recommended to use the full groove width tolerances, especially in the case of thermal expansion.

Installation information:

See pages 38 and 39.

Order information ⁴⁾:

The ring diameter information must match the housing or shaft diameter dimensions "D₁" for all inquiries and/or orders. The rings can be ordered individually or in sets (1 set = 2 ASD rings).

Run and installation tests:

Run and installation tests under operating conditions must be performed in each case before standard production of our laminar rings can begin to determine whether the desired sealing effects can be achieved.

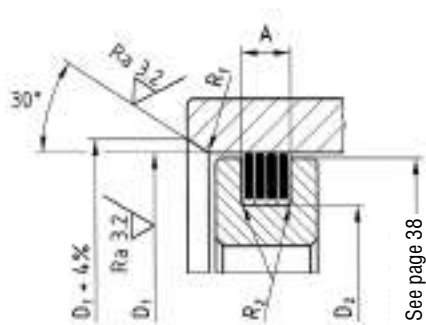
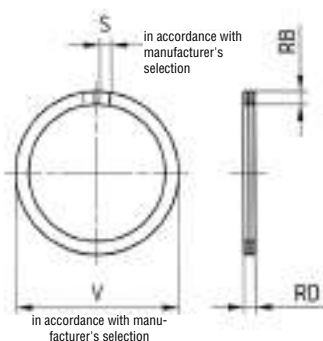

Nominal dimension		Ring dimensions				Groove dimensions					
Bore D ₁	Tolerance	RB	Tolerance	RD	Tolerance	D ₂ = D ₁ minus	Tolerance	A	Tolerance	R ₁	R ₂
15 - 24.9	H 6 H 7	1.0	+ 0.1 - 0.1	1.3	+ 0.08 - 0.04	- 2.6	+ 0 - 0.2	2.9	+ 0.1 - 0	min. 1	0.1
25 - 29.9		1.2		1.3		- 3.0		2.9			
30 - 35.9		1.5		1.3		- 3.6		2.9			
36 - 42.9		1.8		1.3		- 4.2		2.9			
43 - 48.9		2.2		1.45		- 5.0		3.2			
49 - 51.9		2.4		1.45		- 5.4		3.2			
52 - 59.9		2.6		1.45		- 5.8		3.2			
60 - 69.9		2.8		1.65		- 6.2		3.6			
70 - 74.9		3.1		1.65		- 6.8		3.6			
75 - 79.9		3.3		1.65		- 7.2		3.6			
80 - 89.9		3.5		1.65		- 7.6		3.6			
90 - 99.9		3.8		1.65		- 8.2		3.6			
100 - 104.9	H 7 H 8	4.1	+ 0.1 - 0.2	1.65	+ 0.1 - 0.06	- 8.8	+ 0 - 0.25	3.6	+ 0.15 - 0	min. 2	0.2
105 - 109.9		4.3		1.96		- 9.2		4.3			
110 - 119.9		4.6		1.96		- 9.8		4.3			
120 - 129.9		5.0		1.96		- 10.8		4.3			
130 - 149.9		5.5		1.96		- 11.8		4.3			
150 - 170.9		6.0		2.0		- 13.0		4.4			
150 - 170.9	H 8 H 9	*6.0	+ 0.15 - 0.3	3.0	+ 0.12 - 0.08	- 13.0	+ 0 - 0.3	6.5	+ 0.2 - 0	min. 3	0.3
171 - 199.9		7.0		2.0		- 15.0		4.4			
171 - 199.9		*7.0		3.0		- 15.0		6.5			
200 - 259.9		8.0		2.4		- 18.0		5.3			
200 - 259.9		*8.0		3.0		- 18.0		6.5			
260 - 319.9		9.0		3.0		- 20.0		6.5			
320 - 399.9	H 9 H 10	10.0	+ 0.2 - 0.4	3.0	+ 0.14 - 0.1	- 22.0	+ 0 - 0.4	6.6	+ 0.25 - 0	min. 4	0.4
400 - 439.9		11.0		3.0		- 24.0		6.6			
440 - 600.9		12.0		3.0		- 26.0		6.6			
440 - 600.9		*12.0		5.0		- 26.0		10.6			
601 - 699.9		14.0		5.0		- 32.0		10.8			
700 - 799.9		16.0		5.0		- 36.0		10.8			
800 - 899.9	H 9 H 10	18.0	+ 0.2 - 0.4	5.0	+ 0.14 - 0.1	- 40.0	+ 0 - 0.4	11.0	+ 0.25 - 0	min. 4	0.4
900 - 999.9		20.0		5.0		- 44.0		11.0			
1000 - 1300		22.0		5.0		- 48.0		11.0			

All dimensions in mm
 *= reinforced ring design
 Note: Please refer to the information on pages 2, 38, 39, 40 and 41 (questionnaire).
 Please list exact bore or housing diameter "D₁ for all inquiries and orders!

Application "FK6 ASKD" Outside clamping combined double rings (3 rings = 1 set)

Double wound laminar sealing rings "FK6 ASKD" are used as a grease seal for roller and plain bearings and they protect, if greased, against grease leakage as well as against dust, dirt and splash water ingress, especially if the sealing requirements are high. Due to the increased labyrinth effect, the sealing effect is optimized by the additional sealing of the groove base diameter.

The "FK6 ASD" or "FK6 ASKD" assemblies are normally preferred over the "FK6 ISD" or "FK6 ISKD" assemblies due to their easier installation into the grooves. Depending on the applications or the technical requirements, the ring carriers can be manufactured from steel, cast iron, light alloy or plastics.

Ring materials

Steel type	Spring resistant up to	Hardness	Surface protection	Surface color
C75S - DIN 1.0605	max. +300°C	on request ¹⁾	oiled	variable ²⁾
C60E - DIN 1.1221	max. +300°C	on request ¹⁾	oiled	variable ²⁾
50CrV4- DIN 1.8159	max. +400°C	on request ¹⁾	oiled	variable ²⁾
CrNi - DIN 1.4310	max. +450°C	on request ¹⁾	bright and dry	variable ²⁾

¹⁾ Variable depending on the thermal treatment type! Hardness values depending on ring cross section measured in Rockwell HRA or HRC.
²⁾ The surface color can vary depending on the thermal treatment type: bright, light brown or blackened.

Permissible circumferential speed (in m/s)

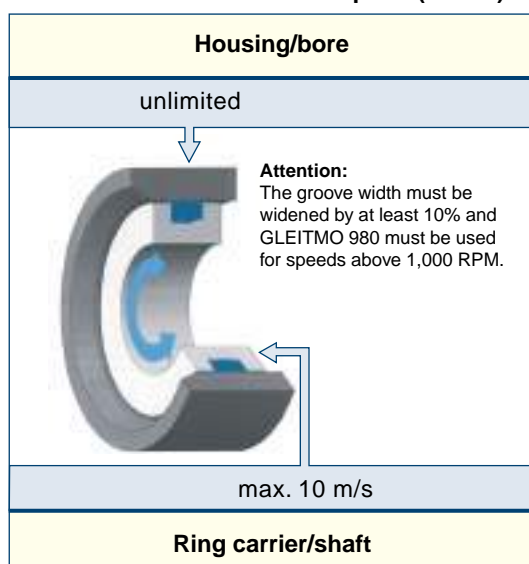

Axial and/or radial play ³⁾

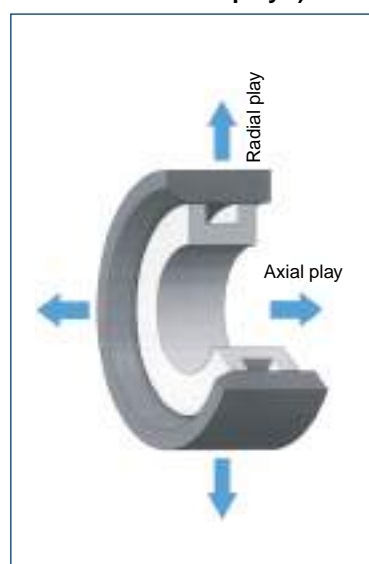

FK6 ASKD ring set ⁴⁾



Axial and/or radial play ³⁾:

The groove width "A" must be widened by twice the play if play occurs in the area of the rings. The groove base diameter "D₂" must be reduced by the radial play if radial play occurs. Damage to the rings and the surrounding components occurs if this is not adhered to. It is recommended to use the full groove width tolerances, especially in the case of thermal expansion.

Installation information:

See pages 38 and 39.

Order information ⁴⁾:

The ring diameter information must match the housing or shaft diameter dimensions "D₁" for all inquiries and/or orders. The rings can be ordered individually or in sets (1 set = 2 ASD rings + 1 ISD rings).

Run and installation tests:

Run and installation tests under operating conditions must be performed in each case before standard production of our laminar rings can begin to determine whether the desired sealing effects can be achieved.

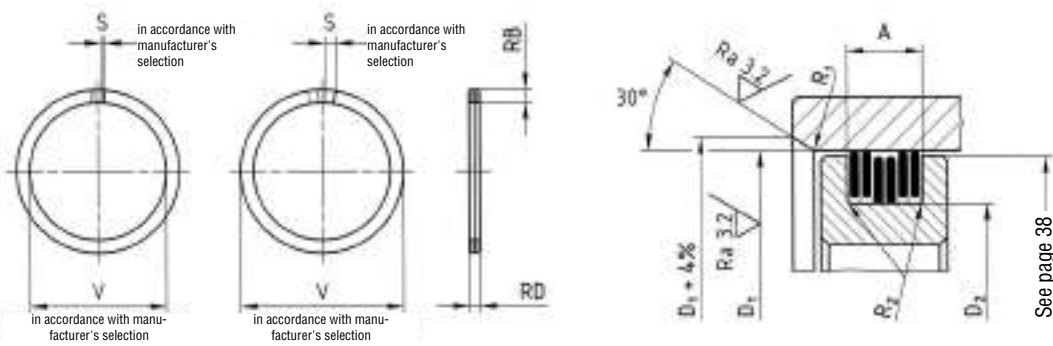

Nominal dimension		Ring dimensions				Groove dimensions					
Bore D ₁	Tolerance	RB	Tolerance	RD	Tolerance	D ₂ = D ₁ minus	Tolerance	A	Tolerance	R ₁	R ₂
15 - 24.9		1.0		1.3		- 2.6		4.3			
25 - 29.9		1.2		1.3		- 3.0		4.3			
30 - 35.9		1.5		1.3		- 3.6		4.3			
36 - 42.9		1.8		1.3		- 4.2		4.3			
43 - 48.9		2.2		1.45		- 5.0		4.8			
49 - 51.9		2.4		1.45		- 5.4		4.8			
52 - 59.9	H 6	2.6	+ 0.1	1.45	+ 0.08	- 5.8	+ 0	4.8	+ 0.1	min. 1	0.1
60 - 69.9	H 7	2.8	- 0.1	1.65	- 0.04	- 6.2	- 0.2	5.4	- 0		
70 - 74.9		3.1		1.65		- 6.8		5.4			
75 - 79.9		3.3		1.65		- 7.2		5.4			
80 - 89.9		3.5		1.65		- 7.6		5.4			
90 - 99.9		3.8		1.65		- 8.2		5.4			
100 - 104.9		4.1		1.65		- 8.8		5.4			
105 - 109.9		4.3		1.96		- 9.2		6.4			
110 - 119.9		4.6		1.96		- 9.8		6.4			
120 - 129.9	H 7	5.0	+ 0.1	1.96	+ 0.1	- 10.8	+ 0	6.4	+ 0.15	min. 2	0.2
130 - 149.9	H 8	5.5	- 0.2	1.96	- 0.06	- 11.8	- 0.25	6.4	- 0		
150 - 170.9		6.0		2.0		- 13.0		6.5			
150 - 170.9		*6.0		3.0		- 13.0		9.6			
171 - 199.9		7.0		2.0		- 15.0		6.5			
171 - 199.9		*7.0		3.0		- 15.0		9.6			
200 - 259.9	H 8	8.0	+ 0.15	2.4	+ 0.12	- 18.0	+ 0	7.8	+ 0.2	min. 3	0.3
200 - 259.9	H 9	*8.0	- 0.3	3.0	- 0.08	- 18.0	- 0.3	9.6	- 0		
260 - 319.9		9.0		3.0		- 20.0		9.6			
320 - 399.9		10.0		3.0		- 22.0		9.8			
400 - 439.9		11.0		3.0		- 24.0		9.8			
440 - 600.9		12.0		3.0		- 26.0		9.8			
440 - 600.9		*12.0		5.0		- 26.0		15.9			
601 - 699.9		14.0		5.0		- 32.0		16.2			
700 - 799.9		16.0		5.0		- 36.0		16.2			
800 - 899.9	H 9	18.0	+ 0.2	5.0	+ 0.14	- 40.0	+ 0	16.5	+ 0.25	min. 4	0.4
900 - 999.9	H 10	20.0	- 0.4	5.0	- 0.1	- 44.0	- 0.4	16.5	- 0		
1000 - 1300		22.0		5.0		- 48.0		16.5			

All dimensions in mm

*= reinforced ring design

Note: Please refer to the information on pages 2, 38, 39, 40 and 41 (questionnaire).

Please list exact bore or housing diameter "D₁ for all inquiries and orders!

Application "FK6 ISD" Inside clamping double rings (2 rings = 1 set)

Double wound laminar sealing rings "FK6 ISD" are used as a grease seal for roller and plain bearings and they protect, if greased, against grease leakage as well as against dust, dirt and splash water ingress, especially if the sealing requirements are high. Double wound laminar rings provide a uniform radial tension and, in contrast to the single wound "FK3" laminar rings, they have no axial joint gap. The combined ring sets "FK6 ISKD" (additional sealing of the groove base diameter) optimize the sealing effect due to the increased labyrinth effect.

The "FK6 ASD" or "FK6 ASKD" assemblies are normally preferred over the "FK6 ISD" or "FK6 ISKD" assemblies due to their easier installation into the grooves. Depending on the applications or the technical requirements, the ring carriers can be manufactured from steel, cast iron, light alloy or plastics.

Ring materials

Steel type	Spring resistant up to	Hardness	Surface protection	Surface color
C75S - DIN 1.0605	max. +300°C	on request ¹⁾	oiled	variable ²⁾
C60E - DIN 1.1221	max. +300°C	on request ¹⁾	oiled	variable ²⁾
50CrV4- DIN 1.8159	max. +400°C	on request ¹⁾	oiled	variable ²⁾
CrNi - DIN 1.4310	max. +450°C	on request ¹⁾	bright and dry	variable ²⁾

¹⁾ Variable depending on the thermal treatment type! Hardness values depending on ring cross section measured in Rockwell HRA or HRC.
²⁾ The surface color can vary depending on the thermal treatment type: bright, light brown or blackened.

Permissible circumferential speed (in m/s)

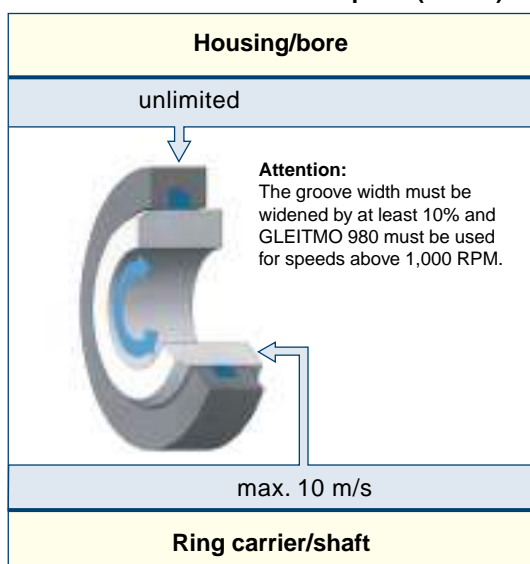

Axial and/or radial play ³⁾

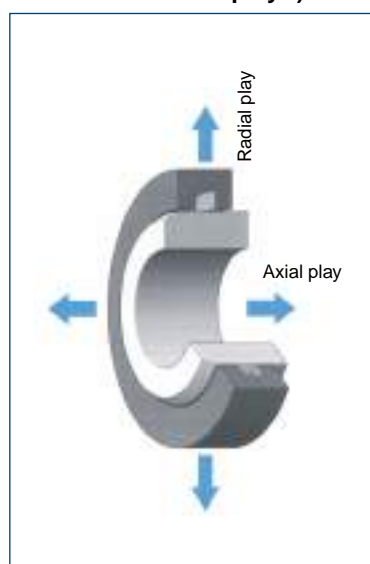

FK6 ISD ring set ⁴⁾



Axial and/or radial play ³⁾:

The groove width "A" must be widened by twice the play if play occurs in the area of the rings. The groove base diameter "D₂" must be increased by the radial play if radial play occurs. Damage to the rings and the surrounding components occurs if this is not adhered to. It is recommended to use the full groove width tolerances, especially in the case of thermal expansion.

Installation information:

See pages 38 and 39.

Order information ⁴⁾:

The ring diameter information must match shaft diameter dimensions "D₁" for all inquiries and/or orders. The rings can be ordered individually or in sets (1 set = 2 ISD rings).

Run and installation tests:

Run and installation tests under operating conditions must be performed in each case before standard production of our laminar rings can begin to determine whether the desired sealing effects can be achieved.

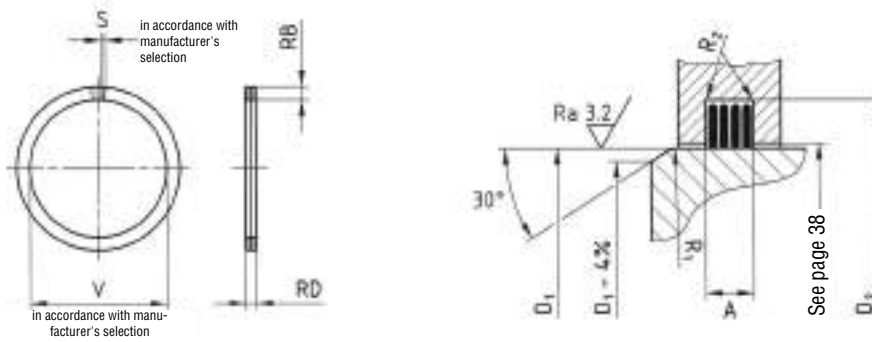

Nominal dimension		Ring dimensions				Groove dimensions					
Shaft D ₁	Tolerance	RB	Tolerance	RD	Tolerance	D ₂ = D ₁ plus	Tolerance	A	Tolerance	R ₁	R ₂
15 - 24.9	h 6 h 7	1.0	+ 0.1 - 0.1	1.3	+ 0.08 - 0.04	+ 2.6	+ 0.2 - 0	2.9	+ 0.1 - 0	min. 1	0.1
25 - 29.9		1.2		1.3		+ 3.0		2.9			
30 - 35.9		1.5		1.3		+ 3.6		2.9			
36 - 42.9		1.8		1.3		+ 4.2		2.9			
43 - 48.9		2.2		1.45		+ 5.0		3.2			
49 - 51.9		2.4		1.45		+ 5.4		3.2			
52 - 59.9		2.6		1.45		+ 5.8		3.2			
60 - 69.9		2.8		1.65		+ 6.2		3.6			
70 - 74.9		3.1		1.65		+ 6.8		3.6			
75 - 79.9		3.3		1.65		+ 7.2		3.6			
80 - 89.9		3.5		1.65		+ 7.6		3.6			
90 - 99.9		3.8		1.65		+ 8.2		3.6			
100 - 104.9	h 7 h 8	4.1	+ 0.1 - 0.2	1.65	+ 0.1 - 0.06	+ 8.8	+ 0.25 - 0	3.6	+ 0.15 - 0	min. 2	0.2
105 - 109.9		4.3		1.96		+ 9.2		4.3			
110 - 119.9		4.6		1.96		+ 9.8		4.3			
120 - 129.9		5.0		1.96		+ 10.8		4.3			
130 - 149.9		5.5		1.96		+ 11.8		4.3			
150 - 170.9		6.0		2.0		+ 13.0		4.4			
150 - 170.9	h 8 h 9	*6.0	+ 0.15 - 0.3	3.0	+ 0.12 - 0.08	+ 13.0	+ 0.3 - 0	6.5	+ 0.2 - 0	min. 3	0.3
171 - 199.9		7.0		2.0		+ 15.0		4.4			
171 - 199.9		*7.0		3.0		+ 15.0		6.5			
200 - 259.9		8.0		2.4		+ 18.0		5.3			
200 - 259.9		*8.0		3.0		+ 18.0		6.5			
260 - 319.9		9.0		3.0		+ 20.0		6.5			
320 - 399.9	h 9 h 10	10.0	+ 0.2 - 0.4	3.0	+ 0.14 - 0.1	+ 22.0	+ 0.4 - 0	6.6	+ 0.25 - 0	min. 4	0.4
400 - 439.9		11.0		3.0		+ 24.0		6.6			
440 - 600.9		12.0		3.0		+ 26.0		6.6			
440 - 600.9		*12.0		5.0		+ 26.0		10.6			
601 - 699.9		14.0		5.0		+ 32.0		10.8			
700 - 799.9		16.0		5.0		+ 36.0		10.8			
800 - 899.9	h 9 h 10	18.0	+ 0.2 - 0.4	5.0	+ 0.14 - 0.1	+ 40.0	+ 0.4 - 0	11.0	+ 0.25 - 0	min. 4	0.4
900 - 999.9		20.0		5.0		+ 44.0		11.0			
1000 - 1300		22.0		5.0		+ 48.0		11.0			

FK 6

ISD

All dimensions in mm

*= reinforced ring design

Note: Please refer to the information on pages 2, 38, 39, 40 and 41 (questionnaire).

Please list exact shaft diameter "D₁" for all inquiries and orders!

Application "FK6 ISKD" Inside clamping combined double rings (3 rings = 1 set)

Double wound laminar sealing rings "FK6 ISKD" are used as a grease seal for roller and plain bearings and they protect, if greased, against grease leakage as well as against dust, dirt and splash water ingress, especially if the sealing requirements are high. Due to the increased labyrinth effect, the sealing effect is optimized by the additional sealing of the groove base diameter.

The "FK6 ASD" or "FK6 ASKD" assemblies are normally preferred over the "FK6 ISD" or "FK6 ISKD" assemblies due to their easier installation into the grooves. Depending on the applications or the technical requirements, the ring carriers can be manufactured from steel, cast iron, light alloy or plastics.

Ring materials

Steel type	Spring resistant up to	Hardness	Surface protection	Surface color
C75S - DIN 1.0605	max. +300°C	on request ¹⁾	oiled	variable ²⁾
C60E - DIN 1.1221	max. +300°C	on request ¹⁾	oiled	variable ²⁾
50CrV4- DIN 1.8159	max. +400°C	on request ¹⁾	oiled	variable ²⁾
CrNi - DIN 1.4310	max. +450°C	on request ¹⁾	bright and dry	variable ²⁾

¹⁾ Variable depending on the thermal treatment type! Hardness values depending on ring cross section measured in Rockwell HRA or HRC.
²⁾ The surface color can vary depending on the thermal treatment type: bright, light brown or blackened.

Permissible circumferential speed (in m/s)



Axial and/or radial play ³⁾

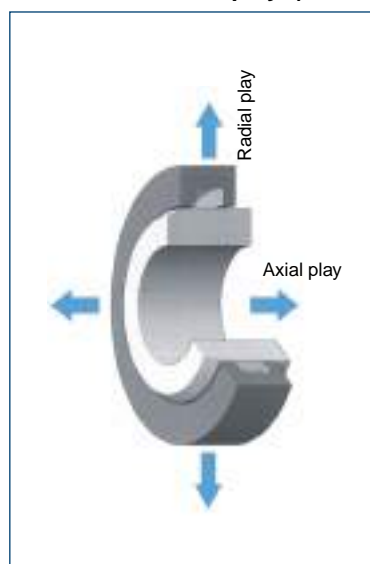

FK6 ISKD ring set ⁴⁾



Axial and/or radial play ³⁾:

The groove width "A" must be widened by twice the play if play occurs in the area of the rings. The groove base diameter "D₂" must be increased by the radial play if radial play occurs. Damage to the rings and the surrounding components occurs if this is not adhered to. It is recommended to use the full groove width tolerances, especially in the case of thermal expansion.

Installation information:

See pages 38 and 39.

Order information ⁴⁾:

The ring diameter information must match shaft diameter dimensions "D₁" for all inquiries and/or orders. The rings can be ordered individually or in sets (1 set = 2 ISD rings + 1 ASD ring).

Run and installation tests:

Run and installation tests under operating conditions must be performed in each case before standard production of our laminar rings can begin to determine whether the desired sealing effects can be achieved.

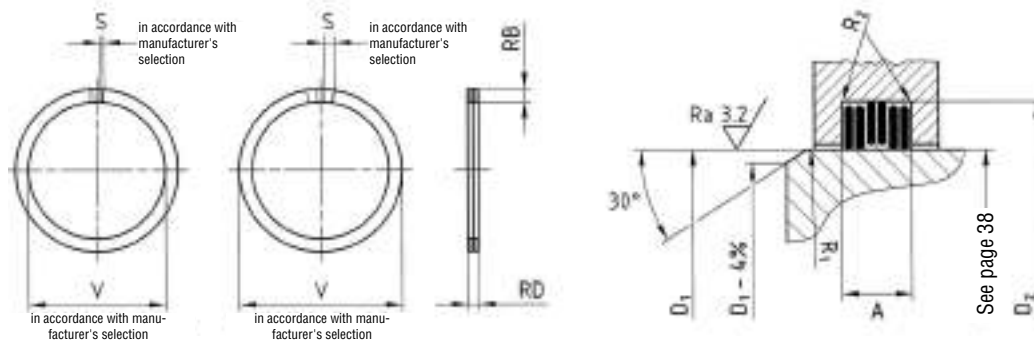

Nominal dimension		Ring dimensions				Groove dimensions					
Shaft D ₁	Tolerance	RB	Tolerance	RD	Tolerance	D ₂ = D ₁ plus	Tolerance	A	Tolerance	R ₁	R ₂
15 - 24.9	h 6 h 7	1.0	+ 0.1 - 0.1	1.3	+ 0.08 - 0.04	+ 2.6	+ 0.2 - 0	4.3	+ 0.1 - 0	min. 1	0.1
25 - 29.9		1.2		1.3		+ 3.0		4.3			
30 - 35.9		1.5		1.3		+ 3.6		4.3			
36 - 42.9		1.8		1.3		+ 4.2		4.3			
43 - 48.9		2.2		1.45		+ 5.0		4.8			
49 - 51.9		2.4		1.45		+ 5.4		4.8			
52 - 59.9		2.6		1.45		+ 5.8		4.8			
60 - 69.9		2.8		1.65		+ 6.2		5.4			
70 - 74.9		3.1		1.65		+ 6.8		5.4			
75 - 79.9		3.3		1.65		+ 7.2		5.4			
80 - 89.9		3.5		1.65		+ 7.6		5.4			
90 - 99.9		3.8		1.65		+ 8.2		5.4			
100 - 104.9	h 7 h 8	4.1	+ 0.1 - 0.2	1.65	+ 0.1 - 0.06	+ 8.8	+ 0.25 - 0	5.4	+ 0.15 - 0	min. 2	0.2
105 - 109.9		4.3		1.96		+ 9.2		6.4			
110 - 119.9		4.6		1.96		+ 9.8		6.4			
120 - 129.9	h 8 h 9	5.0	+ 0.15 - 0.3	1.96	+ 0.12 - 0.08	+ 10.8	+ 0.3 - 0	6.4	+ 0.2 - 0	min. 3	0.3
130 - 149.9		5.5		1.96		+ 11.8		6.4			
150 - 170.9		6.0		2.0		+ 13.0		6.5			
150 - 170.9	h 8 h 9	*6.0	+ 0.15 - 0.3	3.0	+ 0.12 - 0.08	+ 13.0	+ 0.3 - 0	9.6	+ 0.2 - 0	min. 3	0.3
171 - 199.9		7.0		2.0		+ 15.0		6.5			
171 - 199.9		*7.0		3.0		+ 15.0		9.6			
200 - 259.9	h 8 h 9	8.0	+ 0.15 - 0.3	2.4	+ 0.12 - 0.08	+ 18.0	+ 0.3 - 0	7.8	+ 0.2 - 0	min. 3	0.3
200 - 259.9		*8.0		3.0		+ 18.0		9.6			
260 - 319.9		9.0		3.0		+ 20.0		9.6			
320 - 399.9	h 8 h 9	10.0	+ 0.15 - 0.3	3.0	+ 0.12 - 0.08	+ 22.0	+ 0.3 - 0	9.8	+ 0.2 - 0	min. 3	0.3
400 - 439.9		11.0		3.0		+ 24.0		9.8			
440 - 600.9		12.0		3.0		+ 26.0		9.8			
440 - 600.9	h 9 h 10	*12.0	+ 0.2 - 0.4	5.0	+ 0.14 - 0.1	+ 26.0	+ 0.4 - 0	15.9	+ 0.25 - 0	min. 4	0.4
601 - 699.9		14.0		5.0		+ 32.0		16.2			
700 - 799.9		16.0		5.0		+ 36.0		16.2			
800 - 899.9		18.0		5.0		+ 40.0		16.5			
900 - 999.9	20.0	5.0	+ 44.0	16.5							
1000 - 1300	22.0	5.0	+ 48.0	16.5							

FK 6

ISKD

All dimensions in mm

*= reinforced ring design

Note: Please refer to the information on pages 2, 38, 39, 40 and 41 (questionnaire).

Please list exact shaft diameter "D₁" for all inquiries and orders!

Application "FK7 ESB" Single retaining ring bore

The application range for the single wound laminar retaining rings "FK7 ESB" for bores includes applications where the components need to be axially retained, e.g. for transmission systems, construction equipment and agriculture machinery, for fastening elements in the automotive industry and mechanical engineering, in the roller and plain bearing industry, for ship and aircraft building, winches, pulleys, etc.

Assembly/disassembly features are special options for single wound laminar retaining rings (see sketch on page 27).

Ring materials

Steel type	Spring resistant up to	Hardness	Surface protection	Surface color
C75S - DIN 1.0605	max. +300°C	on request ¹⁾	oiled	variable ²⁾
C60E - DIN 1.1221	max. +300°C	on request ¹⁾	oiled	variable ²⁾
50CrV4- DIN 1.8159	max. +400°C	on request ¹⁾	oiled	variable ²⁾
CrNi - DIN 1.4310	max. +450°C	on request ¹⁾	bright and dry	variable ²⁾

¹⁾ Variable depending on the thermal treatment type! Hardness values depending on ring cross section measured in Rockwell HRA or HRC.
²⁾ The surface color can vary depending on the thermal treatment type: bright, light brown or blackened.

Permissible circumferential speed (in m/s)

Housing/bore
unlimited
 <p>Attention: For inquiries and orders, please provide exact bore diameter "D₁", operating temperature and speed!</p>

Axial stress ³⁾

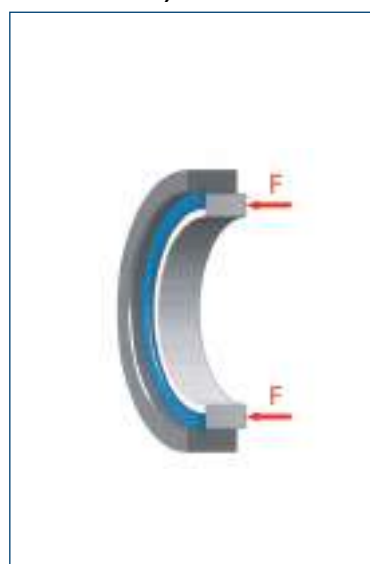

FK7 ESB ring ⁴⁾



Axial stress ³⁾:

Shearing tests under operating conditions must be performed to determine the axial shearing capacity of the retaining rings. The secure position of the retaining rings in the groove cannot be guaranteed if the surrounding components thrust uncontrollable against the laminar rings during operation (coupling effect) or if the components vibrate extremely.

Installation information:

See pages 38 and 39.

Order information ⁴⁾:

The ring diameter information must match bore diameter dimensions "D₁" for all inquiries and/or orders.

Run and installation tests:

Run and installation tests under operating conditions must be performed in each case before standard production of our laminar rings can begin to determine whether the retaining rings can withstand the required stress.

On request
special design
assembly/disassembly features

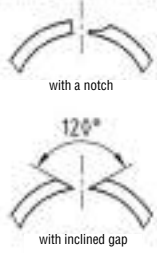

Standard design
(ring end straight)

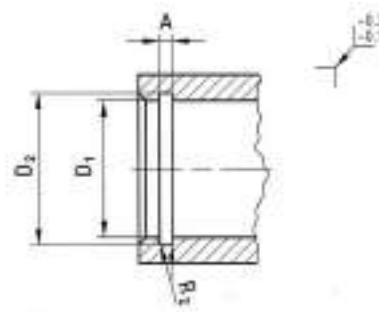
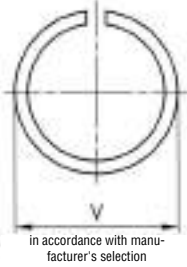

Nominal dimension		Ring dimensions				Groove dimensions				
Bore D ₁	Tolerance	RB	Tolerance	RD	Tolerance	D ₂ = D ₁ plus	Tolerance	A	Tolerance	R ₂
15 - 20.9	H 6 H 7	1.5	+ 0.1 - 0.2	0.65	+ 0.05 - 0.02	+ 0.8	+ 0.1 - 0	0.75	+ 0.05 - 0	0.1
21 - 29.9		1.8		0.65		+ 0.9		0.75		
30 - 35.9		2.2		0.72		+ 1.2		0.85		
36 - 42.9		2.8		0.82		+ 1.6		0.95		
43 - 51.9		3.1		0.82		+ 1.8		0.95		
52 - 59.9		3.5		0.82		+ 2.0		0.95		
60 - 69.9	H 7 H 8	3.8	+ 0.15 - 0.3	0.82	+ 0.08 - 0.04	+ 2.0	+ 0.3 - 0	0.95	+ 0.15 - 0	0.3
70 - 74.9		4.1		0.82		+ 2.5		0.95		
75 - 79.9		4.3		0.98		+ 2.5		1.1		
80 - 89.9		4.6		0.98		+ 2.8		1.1		
90 - 99.9		5.0		0.98		+ 3.0		1.1		
100 - 109.9		5.5		0.98		+ 3.0		1.1		
110 - 129.9	H 8 H 9	6.0	+ 0.2 - 0.4	1.0	+ 0.1 - 0.05	+ 3.5	+ 0.4 - 0	1.15	+ 0.2 - 0	0.4
130 - 149.9		6.0		1.5		+ 3.5		1.65		
150 - 169.9		7.0		1.5		+ 4.0		1.65		
170 - 199.9		8.0		1.5		+ 5.0		1.65		
200 - 259.9		9.0		1.5		+ 5.0		1.65		
260 - 319.9		10.0		1.5		+ 5.5		1.65		
320 - 399.9	H 9 H 10	11.0	+ 0.2 - 0.4	1.5	+ 0.1 - 0.05	+ 6.0	+ 0.4 - 0	1.65	+ 0.2 - 0	0.4
400 - 439.9		12.0		1.5		+ 7.0		1.65		
440 - 599.9		12.0		2.5		+ 7.0		2.7		
600 - 699.9		14.0		2.5		+ 8.0		2.7		
700 - 799.9		16.0		2.5		+ 9.0		2.7		
800 - 899.9		18.0		2.5		+ 10.0		2.7		
900 - 999.9	H 9 H 10	20.0	+ 0.2 - 0.4	2.5	+ 0.1 - 0.05	+ 11.0	+ 0.4 - 0	2.7	+ 0.2 - 0	0.4
1000 - 1300		22.0		2.5		+ 12.0		2.7		

All dimensions in mm

Note: Please refer to the information on pages 2, 38, 39, 40 and 41 (questionnaire).

For inquiries and orders, please provide the exact bore diameter "D₁", operating temperature and speed!

Application "FK7 ESW" Single retaining ring shaft

The application range for the single wound laminar retaining rings "FK7 ESW" for shafts includes applications where the components need to be axially retained, e.g. for transmission systems, construction equipment and agriculture machinery, for fastening elements in the automotive industry and mechanical engineering, in the roller and plain bearing industry, for ship and aircraft building, winches, pulleys, etc.

Assembly/disassembly features are special options for single wound laminar retaining rings (see sketch on page 29).

Ring materials

Steel type	Spring resistant up to	Hardness	Surface protection	Surface color
C75S - DIN 1.0605	max. +300°C	on request ¹⁾	oiled	variable ²⁾
C60E - DIN 1.1221	max. +300°C	on request ¹⁾	oiled	variable ²⁾
50CrV4- DIN 1.8159	max. +400°C	on request ¹⁾	oiled	variable ²⁾
CrNi - DIN 1.4310	max. +450°C	on request ¹⁾	bright and dry	variable ²⁾

¹⁾ Variable depending on the thermal treatment type! Hardness values depending on ring cross section measured in Rockwell HRA or HRC.

²⁾ The surface color can vary depending on the thermal treatment type: bright, light brown or blackened.

Permissible circumferential speed (in m/s)

Attention:
For inquiries and orders, please provide exact shaft diameter "D₁", operating temperature and shaft speed!

max. 4m/s

Shaft/ring carrier

Axial stress ³⁾

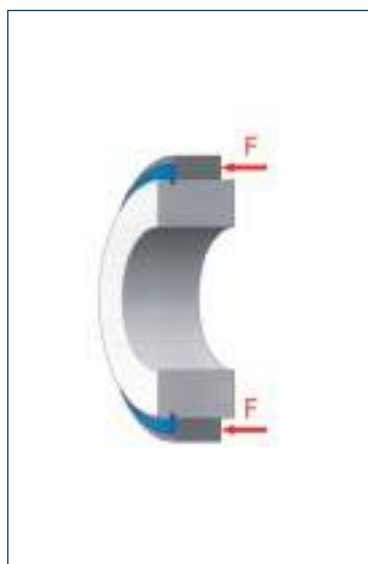

FK7 ESW ring ⁴⁾



Axial stress ³⁾:

Shearing tests under operating conditions must be performed to determine the axial shearing capacity of the retaining rings. The secure position of the retaining rings in the groove cannot be guaranteed if the surrounding components thrust uncontrollable against the laminar rings during operation (coupling effect) or if the components vibrate extremely.

Installation information:

See pages 38 and 39.

Order information ⁴⁾:

The ring diameter information must match shaft diameter dimensions "D₁" for all inquiries and/or orders.

Run and installation tests:

Run and installation tests under operating conditions must be performed in each case before standard production of our laminar rings can begin to determine whether the retaining rings can withstand the required stress.

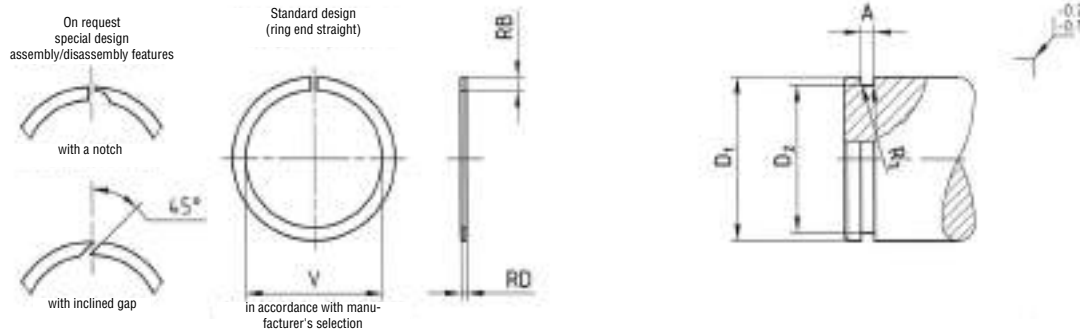

Nominal dimension		Ring dimensions				Groove dimensions										
Shaft D ₁	Tolerance	RB	Tolerance	RD	Tolerance	D ₂ = D ₁ minus	Tolerance	A	Tolerance	R ₂						
15 - 20.9	h 6 h 7	1.5	+ 0.1 - 0.2	0.65	+ 0.05 - 0.02	- 0.8	+ 0 - 0.1	0.75	+ 0.05 - 0	0.1						
21 - 29.9		1.8		0.65		- 0.9		0.75								
30 - 35.9		2.2		0.72		- 1.2		0.85								
36 - 42.9		2.8		0.82		- 1.6		0.95								
43 - 51.9		3.1		0.82		- 1.8		0.95								
52 - 59.9		3.5		0.82		- 2.0		0.95								
60 - 69.9		3.8		0.82		- 2.0		0.95								
70 - 74.9		4.1		0.82		- 2.5		0.95								
75 - 79.9		4.3		0.98		- 2.5		1.1								
80 - 89.9		4.6		0.98		- 2.8		1.1								
90 - 99.9	h 7 h 8	5.0	+ 0.1/-0.2 + 0.15/-0.3	0.98	+ 0.06/-0.03 + 0.08/-0.04	- 3.0	+ 0 - 0.2	1.1	+ 0.1 - 0	0.2						
100 - 109.9		5.5		0.98		- 3.0		1.1								
110 - 129.9	h 8 h 9	6.0	+ 0.15 - 0.3	1.0	+ 0.08 - 0.04	- 3.5	+ 0 - 0.3	1.15	+ 0.15 - 0	0.3						
130 - 149.9		6.0		1.5		- 3.5		1.65								
150 - 169.9		7.0		1.5		- 4.0		1.65								
170 - 199.9		8.0		1.5		- 5.0		1.65								
200 - 259.9		9.0		1.5		- 5.0		1.65								
260 - 319.9		10.0		1.5		- 5.5		1.65								
320 - 399.9		11.0		1.5		- 6.0		1.65								
400 - 439.9		12.0		1.5		- 7.0		1.65								
440 - 599.9		h 9 h 10		12.0		+ 0.2 - 0.4		2.5			+ 0.1 - 0.05	- 7.0	+ 0 - 0.4	2.7	+ 0.2 - 0	0.4
600 - 699.9				14.0				2.5				- 8.0		2.7		
700 - 799.9	16.0		2.5	- 9.0	2.7											
800 - 899.9	18.0		2.5	- 10.0	2.7											
900 - 999.9	20.0		2.5	- 11.0	2.7											
1000 - 1300	22.0	2.5	- 12.0	2.7												

All dimensions in mm

Note: Please refer to the information on pages 2, 38, 39, 40 and 41 (questionnaire).

For inquiries and orders, please provide the exact shaft diameter "D₁", operating temperature and shaft speed!

Application "FK7 DSB" Double retaining ring bore

The double wound laminar retaining rings "FK7 DSB" for bores are a valuable addition to the single wound laminar retaining rings "FK7 ESB".

The application range for the double wound laminar retaining rings "FK7 DSB" for bores includes applications where the components need to be axially retained, e.g. for transmission systems, construction equipment and agriculture machinery, for fastening elements in the automotive industry and mechanical engineering, in the roller and plain bearing industry, for ship and aircraft building, winches, pulleys, etc.

Advantages of the double wound laminar retaining rings:

- Roundness of the closed winding over a range of 360° guarantees fixed contact to the groove base and full circumferential tightness
- Uniform dynamic weight during rotation
- Higher axial resilience as compared to the single wound laminar retaining rings "FK7 ESB"

Ring materials

Steel type	Spring resistant up to	Hardness	Surface protection	Surface color
C75S - DIN 1.0605	max. +300°C	on request ¹⁾	oiled	variable ²⁾
C60E - DIN 1.1221	max. +300°C	on request ¹⁾	oiled	variable ²⁾
50CrV4- DIN 1.8159	max. +400°C	on request ¹⁾	oiled	variable ²⁾
CrNi - DIN 1.4310	max. +450°C	on request ¹⁾	bright and dry	variable ²⁾

¹⁾ Variable depending on the thermal treatment type! Hardness values depending on ring cross section measured in Rockwell HRA or HRC.
²⁾ The surface color can vary depending on the thermal treatment type: bright, light brown or blackened.

Permissible circumferential speed (in m/s)

Housing/bore
unlimited
 <p>Attention: For inquiries and orders, please provide exact bore diameter "D₁", operating temperature and speed!</p>

Axial stress ³⁾

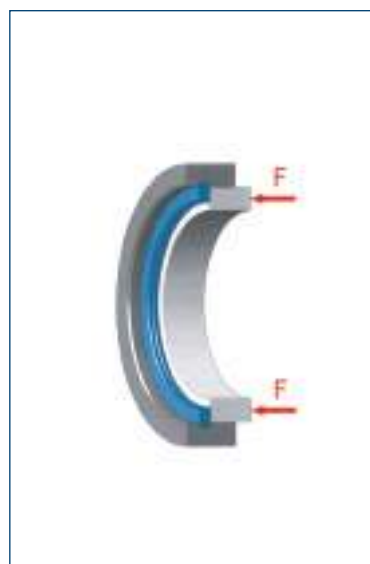

FK7 DSB ring ⁴⁾



Axial stress ³⁾:

Shearing tests under operating conditions must be performed to determine the axial shearing capacity of the retaining rings. The secure position of the retaining rings in the groove cannot be guaranteed if the surrounding components thrust uncontrollable against the laminar rings during operation (coupling effect) or if the components vibrate extremely.

Installation information:

See pages 38 and 39.

Order information ⁴⁾:

The ring diameter information must match bore diameter dimensions "D₁" for all inquiries and/or orders.

Run and installation tests:

Run and installation tests under operating conditions must be performed in each case before standard production of our laminar rings can begin to determine whether the retaining rings can withstand the required stress.

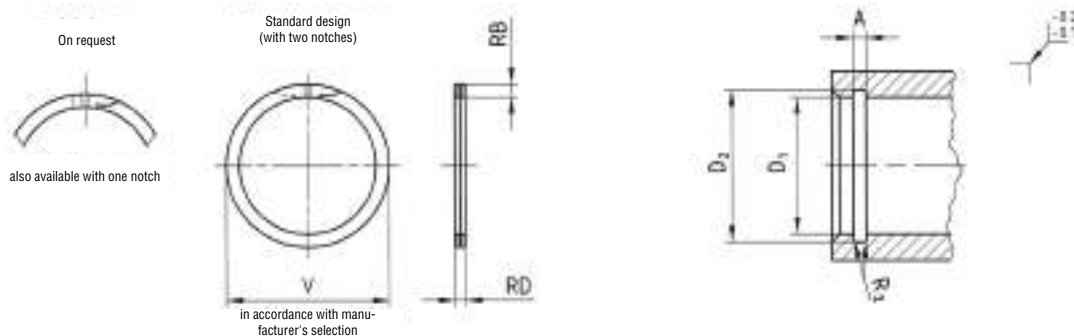

Nominal dimension		Ring dimensions				Groove dimensions				
Bore D ₁	Tolerance	RB	Tolerance	RD	Tolerance	D ₂ = D ₁ plus	Tolerance	A	Tolerance	R ₂
15 - 20.9 21 - 29.9	H 6 H 7	1.5 1.8	+ 0.1 - 0.2	1.3 1.3	+ 0.1 - 0.04	+ 0.8 + 0.9	+ 0.1 - 0	1.45 1.45	+ 0.05 - 0	0.1
30 - 35.9 36 - 42.9		2.2 2.8		1.45 1.65		+ 1.2 + 1.6		1.6 1.8		
43 - 51.9 52 - 59.9		3.1 3.5		1.65 1.65		+ 1.8 + 2.0		1.8 1.8		
60 - 69.9 70 - 74.9		3.8 4.1		1.65 1.65		+ 2.0 + 2.5		1.8 1.8		
75 - 79.9 80 - 89.9		4.3 4.6		1.98 1.98		+ 2.5 + 2.8		2.15 2.15		
90 - 99.9 100 - 109.9		5.0 5.5		1.98 1.98		+ 3.0 + 3.0		2.15 2.15		
110 - 129.9 130 - 149.9	H 7 H 8	6.0 6.0	+0.1/-0.2 +0.15/-0.3	2.0 3.0	+0.12/-0.06 +0.15/-0.08	+ 3.5 + 3.5	+ 0.2 - 0	2.2 3.2	+0.1/-0 +0.15/-0	0.2
150 - 169.9 170 - 199.9	H 8 H 9	7.0 8.0	+ 0.15 - 0.3	3.0 3.0	+ 0.15 - 0.08	+ 4.0 + 5.0		3.2 3.2	+ 0.15 - 0	0.3
200 - 259.9 260 - 319.9		9.0 10.0		3.0 3.0		+ 5.0 + 5.5		3.2 3.2		
320 - 399.9 400 - 439.9		11.0 12.0		3.0 3.0		+ 6.0 + 7.0		3.2 3.2		
440 - 599.9 600 - 699.9		12.0 14.0		5.0 5.0		+ 7.0 + 8.0		5.3 5.3		
700 - 799.9 800 - 899.9	H 9 H 10	16.0 18.0	+ 0.2 - 0.4	5.0 5.0	+ 0.2 - 0.1	+ 9.0 + 10.0		+ 0.4 - 0	5.3 5.3	+ 0.2 - 0
900 - 999.9 1000 - 1300		20.0 22.0	5.0 5.0	+ 11.0 + 12.0	5.3 5.3					



All dimensions in mm

Note: Please refer to the information on pages 2, 38, 39, 40 and 41 (questionnaire).

For inquiries and orders, please provide the exact bore diameter "D₁", operating temperature and speed!

Application "FK7 DSW" Double retaining ring shaft

The double wound laminar retaining rings "FK7 DSW" for shafts are a valuable addition to the single wound laminar retaining rings "FK7 ESW".

The application range for the double wound laminar retaining rings "FK7 DSW" for shafts includes applications where the components need to be axially retained, e.g. for transmission systems, construction equipment and agriculture machinery, for fastening elements in the automotive industry and mechanical engineering, in the roller and plain bearing industry, for ship and aircraft building, winches, pulleys, etc.

Advantages of the double wound laminar retaining rings:

- Roundness of the closed winding over a range of 360° guarantees fixed contact to the groove base and full circumferential tightness
- Uniform dynamic weight during rotation
- Higher axial resilience as compared to the single wound laminar retaining rings "FK7 ESW"

Ring materials

Steel type	Spring resistant up to	Hardness	Surface protection	Surface color
C75S - DIN 1.0605	max. +300°C	on request ¹⁾	oiled	variable ²⁾
C60E - DIN 1.1221	max. +300°C	on request ¹⁾	oiled	variable ²⁾
50CrV4- DIN 1.8159	max. +400°C	on request ¹⁾	oiled	variable ²⁾
CrNi - DIN 1.4310	max. +450°C	on request ¹⁾	bright and dry	variable ²⁾

¹⁾ Variable depending on the thermal treatment type! Hardness values depending on ring cross section measured in Rockwell HRA or HRC.

²⁾ The surface color can vary depending on the thermal treatment type: bright, light brown or blackened.

Permissible circumferential speed (in m/s)



Attention:
For inquiries and orders,
please provide exact shaft
diameter "D₁", operating
temperature and shaft speed!

max. 10 m/s

Shaft/ring carrier

Axial stress ³⁾

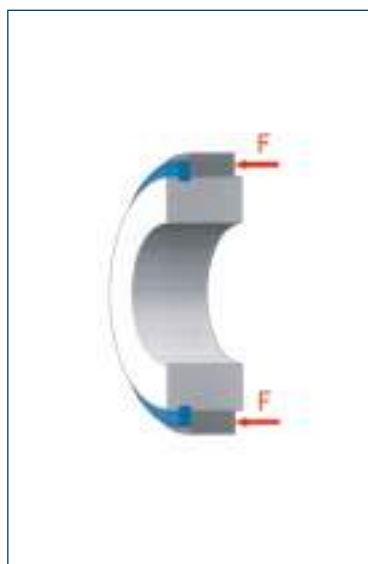

FK7 DSW ring ⁴⁾



Axial stress ³⁾:

Shearing tests under operating conditions must be performed to determine the axial shearing capacity of the retaining rings. The secure position of the retaining rings in the groove cannot be guaranteed if the surrounding components thrust uncontrollable against the laminar rings during operation (coupling effect) or if the components vibrate extremely.

Installation information:

See pages 38 and 39.

Order information ⁴⁾:

The ring diameter information must match shaft diameter dimensions "D₁" for all inquiries and/or orders.

Run and installation tests:

Run and installation tests under operating conditions must be performed in each case before standard production of our laminar rings can begin to determine whether the retaining rings can withstand the required stress.

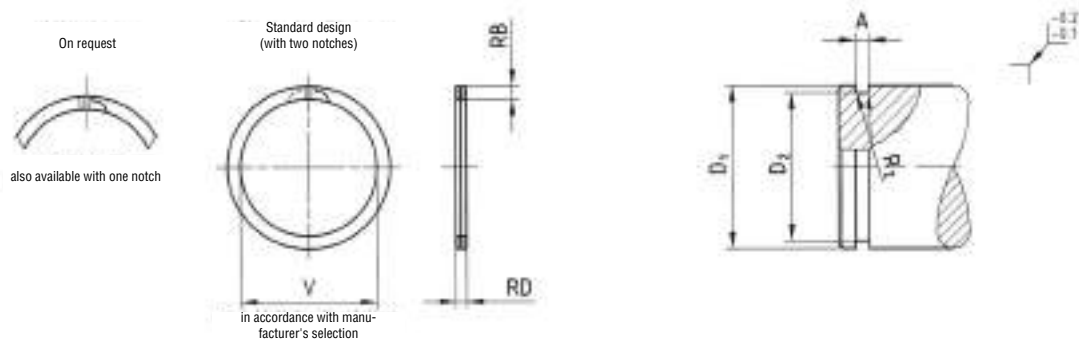

Nominal dimension		Ring dimensions				Groove dimensions										
Shaft D ₁	Tolerance	RB	Tolerance	RD	Tolerance	D ₂ = D ₁ minus	Tolerance	A	Tolerance	R ₂						
15 - 20.9 21 - 29.9	h 6 h 7	1.5 1.8	+ 0.1 - 0.2	1.3 1.3	+ 0.1 - 0.04	- 0.8 - 0.9	+ 0 - 0.1	1.45 1.45	+ 0.05 - 0	0.1						
30 - 35.9 36 - 42.9		2.2 2.8		1.45 1.65		- 1.2 - 1.6		1.6 1.8								
43 - 51.9 52 - 59.9		3.1 3.5		1.65 1.65		- 1.8 - 2.0		1.8 1.8								
60 - 69.9 70 - 74.9		3.8 4.1		1.65 1.65		- 2.0 - 2.5		1.8 1.8								
75 - 79.9 80 - 89.9		4.3 4.6		1.98 1.98		- 2.5 - 2.8		2.15 2.15								
90 - 99.9 100 - 109.9		5.0 5.5		1.98 1.98		- 3.0 - 3.0		2.15 2.15								
110 - 129.9 130 - 149.9		h 7 h 8		6.0 6.0		+0.1/-0.2 +0.15/-0.3		2.0 3.0			+0.12/-0.06 +0.15/-0.08	- 3.5 - 3.5	+ 0 - 0.2	2.2 3.2	+0.1/-0 +0.15/-0	0.2
150 - 169.9 170 - 199.9		7.0 8.0		3.0 3.0		- 4.0 - 5.0		3.2 3.2								
200 - 259.9 260 - 319.9		9.0 10.0		3.0 3.0		- 5.0 - 5.5		3.2 3.2								
320 - 399.9 400 - 439.9		h 8 h 9		11.0 12.0		3.0 3.0		- 6.0 - 7.0			3.2 3.2					
440 - 599.9 600 - 699.9	12.0 14.0	5.0 5.0	- 7.0 - 8.0	5.3 5.3												
700 - 799.9 800 - 899.9	16.0 18.0	5.0 5.0	- 9.0 - 10.0	5.3 5.3												
900 - 999.9 1000 - 1300	h 9 h 10	20.0 22.0	5.0 5.0	- 11.0 - 12.0	5.3 5.3											

↑
All dimensions in mm
Note: Please refer to the information on pages 2, 38, 39, 40 and 41 (questionnaire).
For inquiries and orders, please provide the exact shaft diameter "D₁", operating temperature and shaft speed!

FK 7 DMS

Double laminar retaining rings for shafts (with centrifugal force protection)

Application "FK7 DMS" Double retaining ring shaft with centrifugal force protection

"FK7 DMS" double laminar retaining rings with centrifugal force protection can be used for rotational speeds that cannot be achieved by "FK7 DSW" retaining rings.

Diameter range for DMS rings:

Ø 45 mm to Ø 310 mm.

Ring materials

Steel type	Spring resistant up to	Hardness	Surface protection	Surface color
C75S - DIN 1.0605	max. +300°C	on request ¹⁾	oiled	variable ²⁾
C60E - DIN 1.1221	max. +300°C	on request ¹⁾	oiled	variable ²⁾
50CrV4- DIN 1.8159	max. +400°C	on request ¹⁾	oiled	variable ²⁾
CrNi - DIN 1.4310	max. +450°C	on request ¹⁾	bright and dry	variable ²⁾

¹⁾ Variable depending on the thermal treatment type! Hardness values depending on ring cross section measured in Rockwell HRA or HRC.
²⁾ The surface color can vary depending on the thermal treatment type: bright, light brown or blackened.

Permissible circumferential speed (in m/s)



Axial stress ³⁾

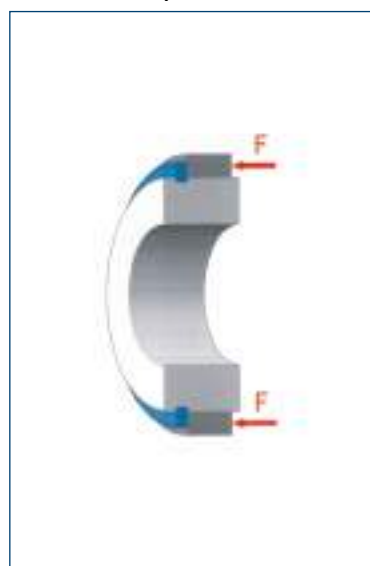

FK7 DMS ring ⁴⁾



Axial stress ³⁾:

Shearing tests under operating conditions must be performed to determine the axial shearing capacity of the retaining rings. The secure position of the retaining rings in the groove cannot be guaranteed if the surrounding components thrust uncontrollable against the laminar rings during operation (coupling effect) or if the components vibrate extremely.

Installation information:

See pages 38 and 39.

Order information ⁴⁾:

The ring diameter information must match shaft diameter dimensions "D₁" for all inquiries and/or orders.

Run and installation tests:

Run and installation tests under operating conditions must be performed in each case before standard production of our laminar rings can begin to determine whether the retaining rings can withstand the required stress.

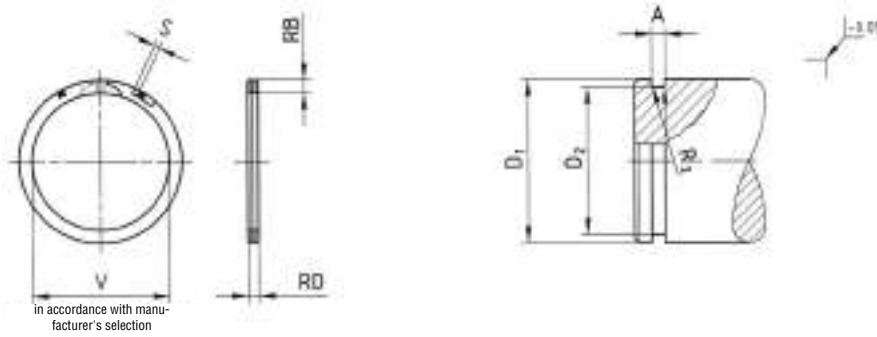

Nominal dimension		Ring dimensions				Groove dimensions					
Shaft D ₁	Tolerance	RB	Tolerance	RD	Tolerance	D ₂ = D ₁ minus	Tolerance	A	Tolerance	S	R ₂
45 - 51.9	h 7	3.5	+ 0.1 - 0.1	1.65	+ 0.1 - 0	- 2.0	+ 0 - 0.05	1.8	+ 0.05 - 0	max. 1.0	max. 0.1
52 - 59.9		3.5		1.65		- 2.0		1.8			
60 - 69.9		3.8		1.65		- 2.0		1.8			
70 - 74.9		4.1	+ 0.1 - 0.2	1.65		- 2.5		1.8			
75 - 79.9		4.3		1.98		- 2.5		2.15			
80 - 89.9		4.6		1.98		- 2.8		2.15			
90 - 99.9		5.0	+ 0.15 - 0.3	1.98		- 3.0		2.15			
100 - 109.9		5.5		1.98		- 3.0		2.15			
110 - 129.9		6.0		2.0		- 3.5		2.15			
130 - 149.9		6.0	+ 0.15 - 0.3	3.0		- 3.5		3.15			
150 - 169.9		7.0		3.0		- 4.0		3.15			
170 - 199.9		8.0		3.0		- 5.0		3.15			
200 - 259.9	9.0	+ 0.15 - 0.3	3.0	- 5.0	3.15						
260 - 310	10.0		3.0	- 5.5	3.15						

All dimensions in mm
Attention: Please refer to the information on pages 2, 38, 39, 40 and 41 (questionnaire).
For inquiries and orders, please provide the exact shaft diameter "D₁", operating temperature and shaft speed!

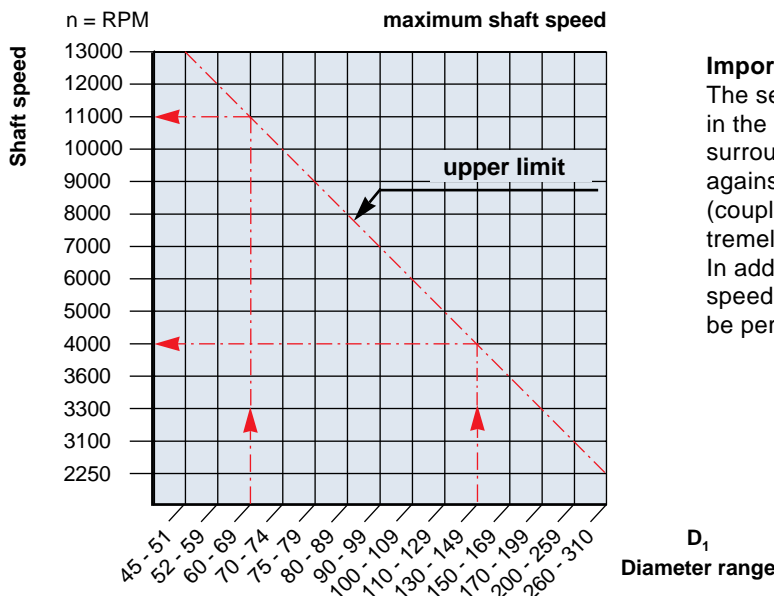

Important information:
 The secure position of the "FK7 DMS" rings in the groove cannot be guaranteed if the surrounding components thrust uncontrollable against the laminar rings during operation (coupling effect) or if the shafts vibrate extremely.
 In addition to the stated max. permissible shaft speed, installation and long term run tests must be performed under operating conditions.

Application "FK8" plastic laminar ring carrier seals

Outside clamping plastic ring carrier seals made from Polyamide 6 (PA6), also available with mineral fibre fortification, are used to seal roller bearings against grease leakage or dirt and splash water ingress in vehicle axles as well as rollers and wheels for all equipment types, engines in transport technology, motion sequences in construction equipment and agriculture machines.

Ring carrier seals in accordance with design 01 and 02 have spring-loaded, flexible sealing lips. This has advantages if splash water can frequently be expected in the sealing area.

Plastic ring carrier seals are also suitable as a protection seal in front of radial shaft seal arrangements.

Materials

Plastic type	reinforced design	Application temperature	Laminar ring material
PA6 (Polyamide 6)	-	-40°C to 120°C ¹⁾	C75S - DIN 1.0605 ³⁾ CrNi - DIN 1.4310 ³⁾
PA6 ²⁾ (Polyamide 6)	Mineral fibre reinforced	-40°C to 120°C ¹⁾	CrNi - DIN 1.4571 ³⁾

¹⁾ Temperature resistance at -40°C to +120°C unlimited, short term temperature resistance at max. +150°C.

²⁾ Not all ring carrier sizes are available with the reinforced design; for details please contact our technical office.

³⁾ Depending on the requirements, the following laminar ring materials are available; please include the laminar ring material in your order.

Application examples:



Installation:

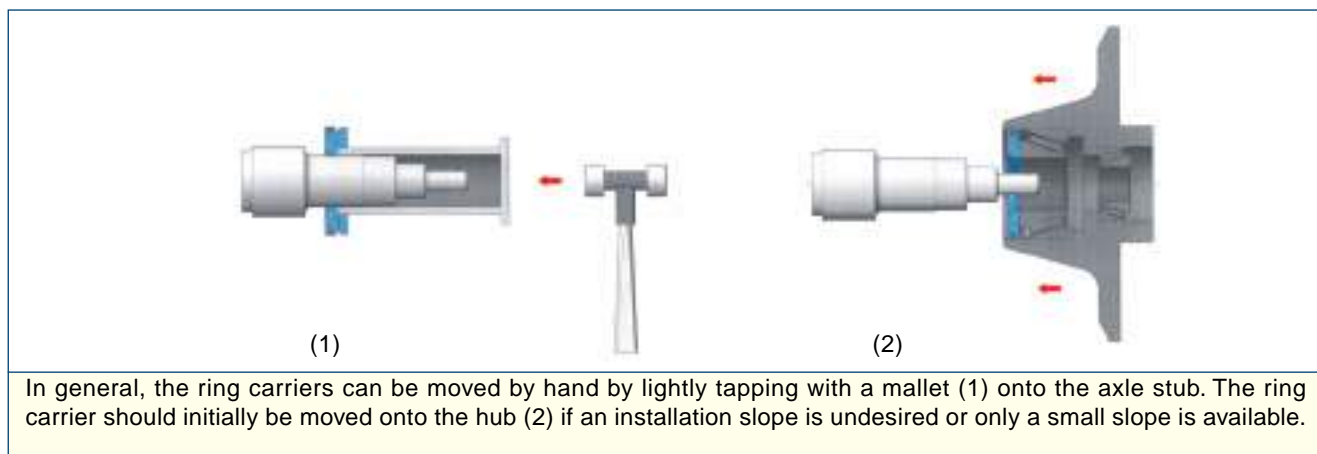

Run and installation tests:

Run and installation tests under operating conditions must be performed in each case before standard production of our ring carrier seals can begin to determine whether the desired sealing effects can be achieved.

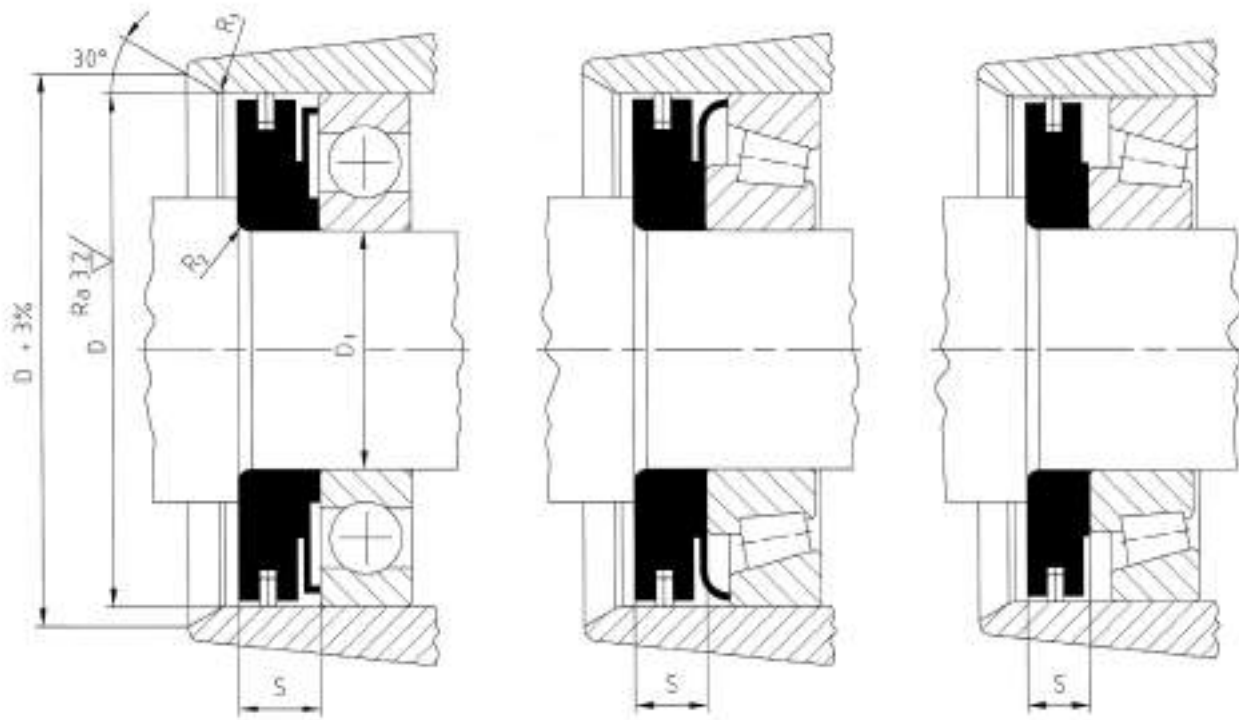

Design 01:
Ring carrier with a short
sealing lip for symmetrical
roller bearings

Design 02
Ring carrier with a long
sealing lip for tapered
roller bearings

Design 03:
Ring carrier without
sealing lip

Design			Bore		Shaft		Ring carrier		Order information	
01	02	03	D	R ₁	D ₁	R ₂	S	Material	Product number	
●			47	1	20	1	7.7	PA6 (Polyamid 6)	472077 R1	
●			47		25	2	7.7		472577 R1	
●			52	2	25	3	6		52256 R1	
●			62		30		7		62307 R1	
●			72		35		7		72357 R1	
	●		52	1	25	PA6 (Polyamid 6)	6		52256 K1	
	●		55		30		7		55307 K1	
	●		62	2	30		7		62307 K1	
	●		62		35		7		62357 K1	
	●		72		35		7		72357 K1	
		●	80	2	40		3.5		7	80407
		●	85		45		4		7	85457
		●	90	3	50		3.5		6	90506
		●	90		50		4		7.5	905075
		●	100		55				4	8
		●	110	3	60		5		8	110608
		●	120		65				4.5	9
		●	125	3	70		6		10	1257010
		●	125		80				5	10
		●	140	3	80		6		9	140809
		●	150		85			6	14	1508514
		●	150	3	100		6	14	15010014	
		●	150		100			6	14	15010014

All dimensions in mm

Attention: Please refer to the information on pages 2, 38, 39, 40 and 41 (questionnaire).

For inquiries and orders, please provide the bore diameter "D" and the product number; additionally, please provide information about the operating temperature.

Fig. 1

The design for gaps (A) must be as small as possible. The smaller the gap the larger the labyrinth or sealing effect.

Please refer to the information in the respective data sheets for the different ring designs under "Axial and/or radial play" if radial play and/or tilting motions are detected!

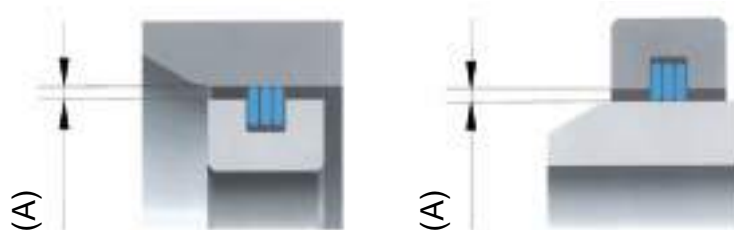

Fig. 2

The use of attachable installation tools for the housings and removable installation tools for shafts are recommended if the specified installation chamfers are not possible at the housing or shaft for space reasons.

Do not only press when assembling the parts equipped with rings but overcome the slip resistance by radial motion and axial tapping.

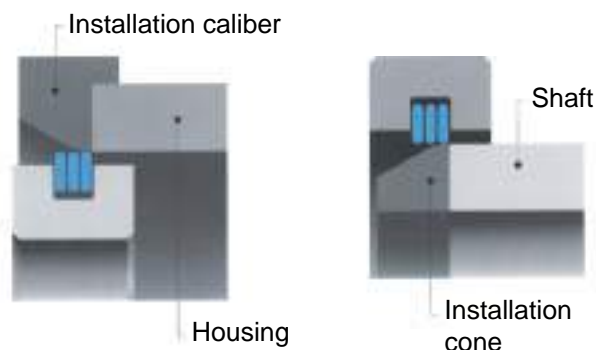

Fig. 3:

- 1) Single and double wound laminar rings are spiraled into the grooves by axially spreading the rings.
- 2) Care must be taken to ensure the rings are not over stretched, as they will be permanently deformed.

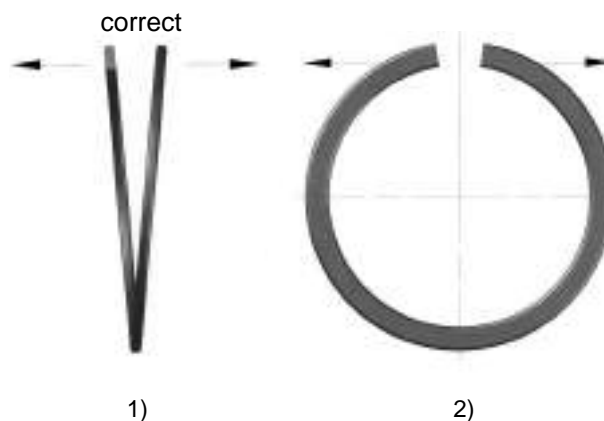

Fig. 4:

Do not spiral the ring ends into each other or jam them when the single wound laminar rings are spiraled into the grooves.

Do not spiral the ring ends or the windings into each other or jam them when the double wound laminar rings are spiraled into the grooves.

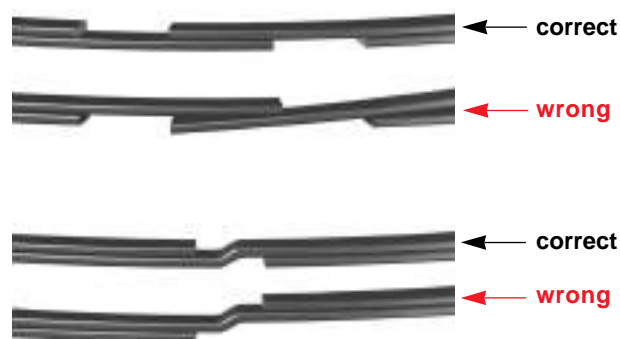

Fig. 5

As shown, inside and outside clamping laminar rings can be installed through spiraling by hand.

Spread ring slightly axially

- 1) Insert one ring end into the groove
- 2) Slide remaining part of the ring spirally

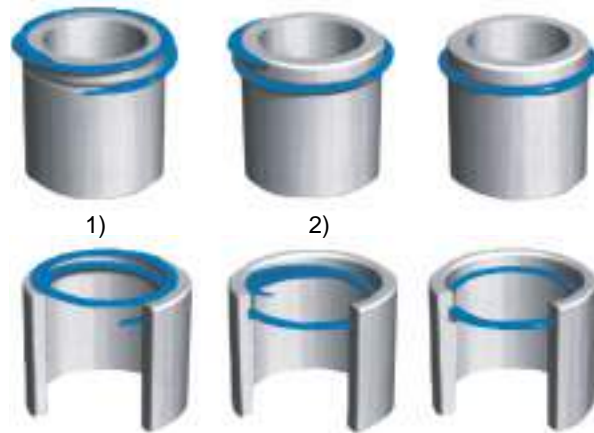

Fig. 6

The shaft retaining rings can also be installed with a support tool (see figure) to replace spiraling by hand.

- 1) Attach installation cone and retaining ring.
- 2) Slide the retaining ring with the help of the push sleeve over the installation cone.
- 3) Check the secure installation of the ring in the groove.

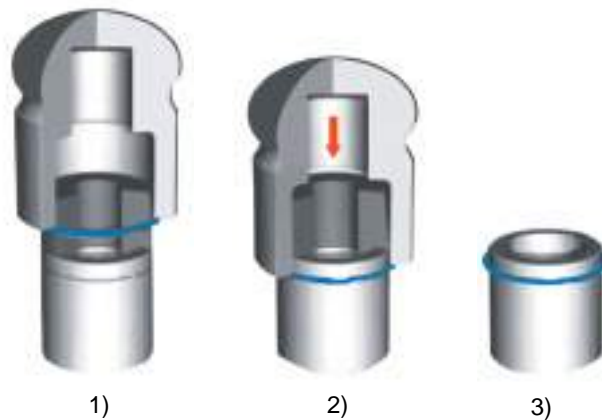

Fig. 7:

The bore retaining rings can also be installed with a support tool (see figure) to replace spiraling by hand.

- 1) Attach installation tapered sleeve and retaining ring.
- 2) Slide the retaining ring with the help of the push sleeve over the installation tapered sleeve.
- 3) Check the secure installation of the ring in the groove.

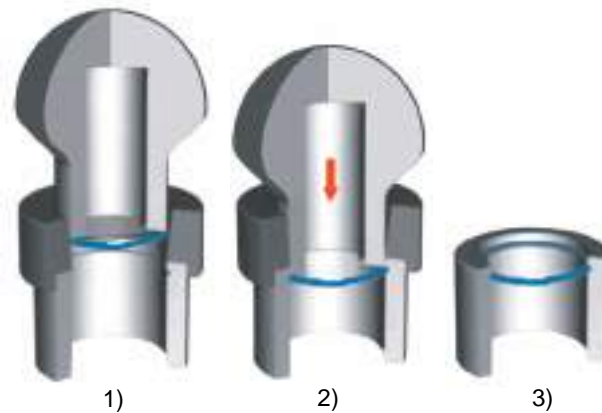

Fig. 8:

Disassembly of the retaining rings with the help of a flat-bladed screwdriver. The screwdriver is inserted into the disassembly notch and rotated slightly so that one ring end of the retaining ring slides out of the groove.

The ring will be removed spirally from the groove.



General information for greasing:

Greased laminar rings provide a better seal arrangement than dry running rings, greased laminar rings are required when the application is subject to splash water, dirt and scale. In order to allow sufficient transfer of grease throughout arrangement and prevent over pressure during application, it is recommended that grease application bores and grease relief bores are provided. Where possible the ring carrier should be supplied by 4 off 3 to 5 mm diameter bores equally distributed around the circumference and also into the groove base, this will allow easy application and exchange of grease during re-lubrication.

Greasing options:

Listed below are three different and proven greasing options with greasing bores or grease relief bores, which can be arranged depending on the available space. Leakes from the outside are not possible because the bores are filled with grease.

Lubrication recommendation:

We cannot make any recommendations for the selection of the lubricant or provide information about the greasing frequency. The type and quantity of an appropriate lubricant must be determined and specified by the customer depending on the operating conditions such as speed, operating temperatures, contamination level and ambient conditions. Bearing and lubricant manufacturers may be able to provide information.

Note:

The "FK5-HFL" ring types are the exception with respect to greasing. They must be installed dry and without any additional lubricants. The surrounding components, which come in contact with the laminar rings must also not be greased. The lubricants carbonize due to the high operating temperatures and the laminar rings will fail.

Application examples:

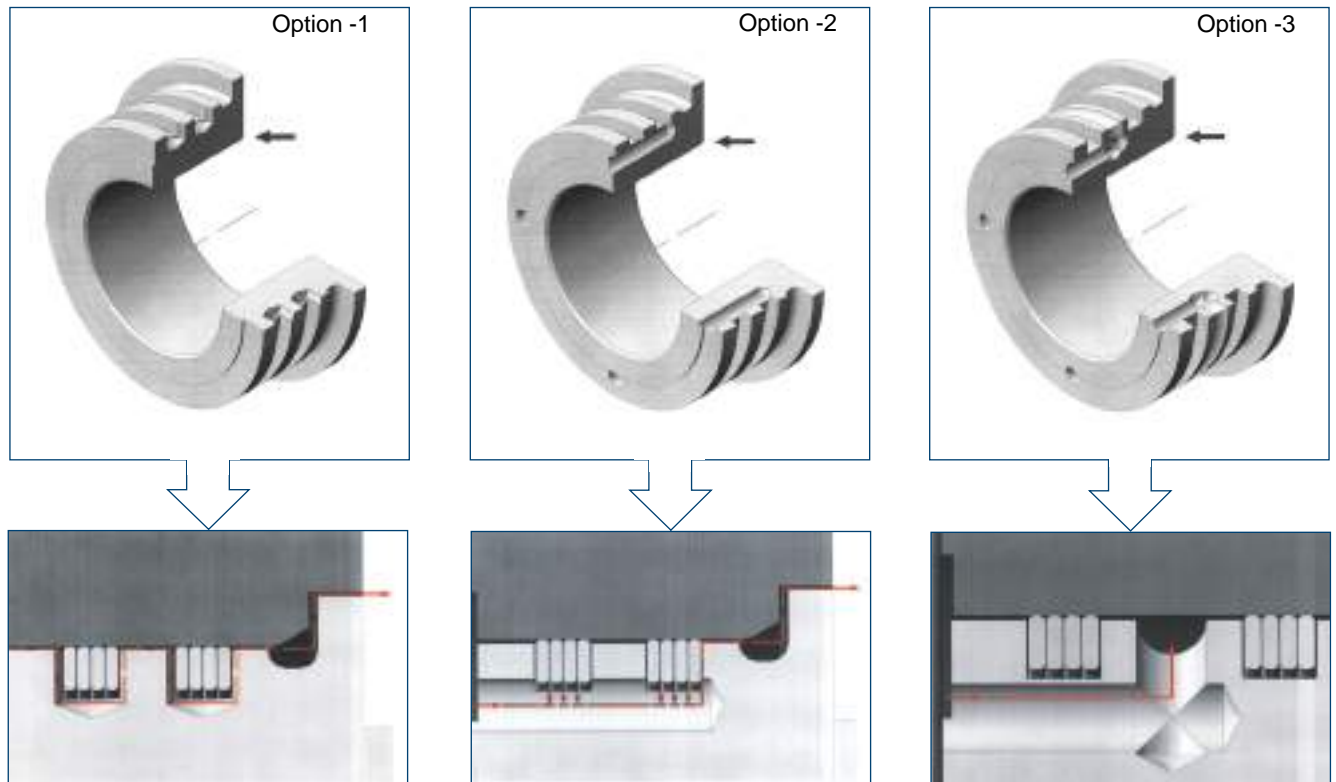

Option -1:

Grease relief bores, arranged vertically to the groove base, four for each groove circumferentially distributed at 90°. The bore diameter depends on the groove width. The grease pressed by the bearings can flow in next to the rings or can flow out upwards under the rings.

Option -2:

Grease relief bores, arranged horizontally to the groove base, four for each groove circumferentially distributed at 90°. The bore diameter should be between 3 and 5 mm. The grease pressed by the bearings can flow out upwards under the rings (groove base diameter) and next to the rings.

Option -3:

This greasing option is a combination of the above mentioned option 1 and 2. A so-called "grease chamber" is placed between the two sealing ring sets, this will act as a grease reservoir in the groove and therefore optimize the sealing effect.



Company address

Person in charge Department

Phone Fax

E-mail Date

Machine type Project No.

- The laminar rings must seal against?
 - Splash water entry Severe contamination Cooling lubricant entry Dust entry
 - Oil leakage Grease leakage Other media:
- Protect other seals yes / which no
- Operating temperature (in ring area °C)
- Housing speed (RPM / rotational direction)
- Shaft speed (RPM / rotational direction)
- Axial movement yes / in mm no
- Radial movement yes / in mm no
- Angular movement yes / in ° no
- Operating pressure (Medium) yes / in bar no
- Re-greasing option yes / which no
- Stainless steel laminar rings yes no
- Housing materials (hardened) yes / hardness no
- Shaft material (hardened) yes / hardness no
- New design yes no
- Changeover to laminar rings yes no
- Which type of sealing was used before?
- Permissible leakage
- Lifespan
- What would the demand be:
 - one time (pieces/set)
 - monthly (pieces/set)
 - annually (pieces/set)

Additional questions for the use of Fey retainer rings:

- Will the retaining rings be axially loaded (against)
- How large is the axial load against the rings (in N)
- Will the disassembly notches be required?

➤ Please make a CAD drawing or a dimensioned sketch available so that we can analyze the installation situation! ◀

Example 01

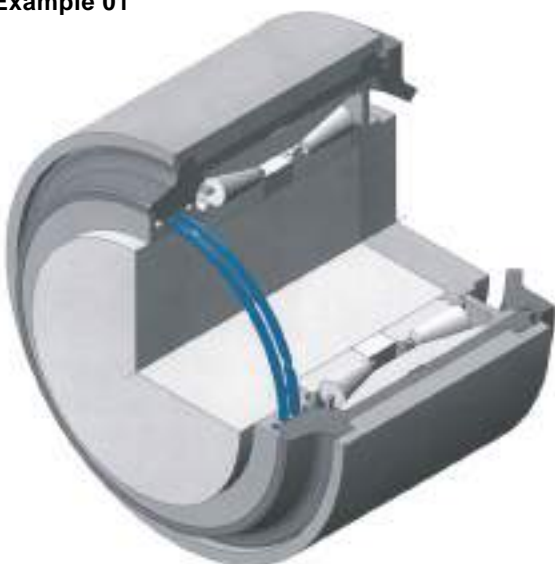

Example 02

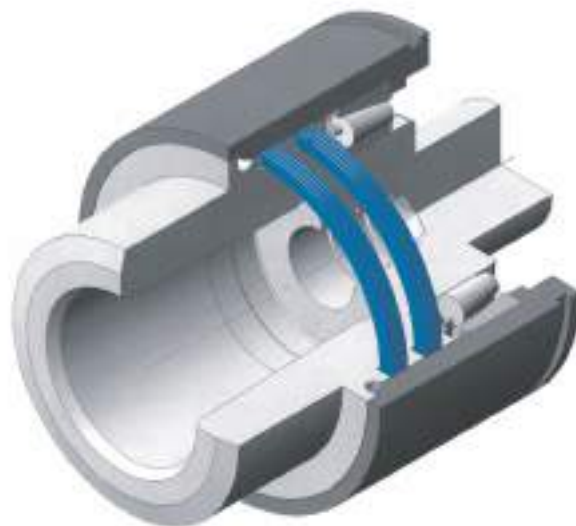

Example 03



Example 04

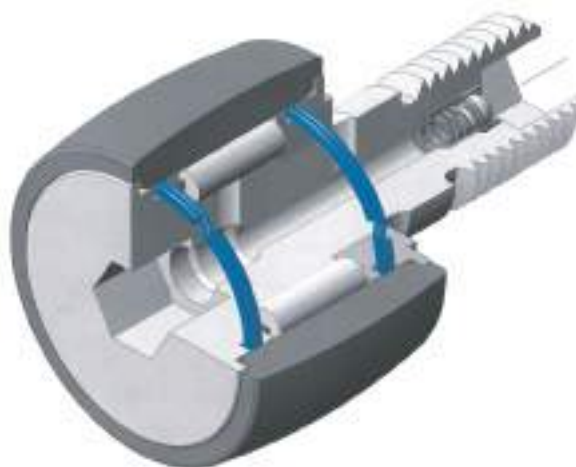

Example 05

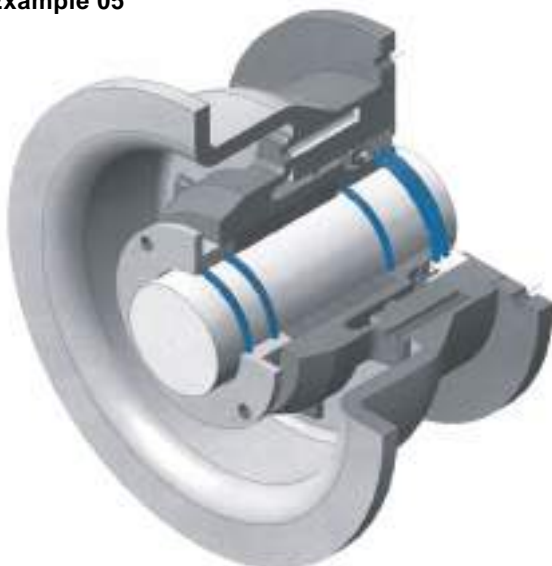

Example 06



Samples
DE 203 16 372.9
European patent registration
No. 047 868 59.1
Canadian patent registration
No. 254 22 42
US patent registration
No. 10/576,869

Example 07

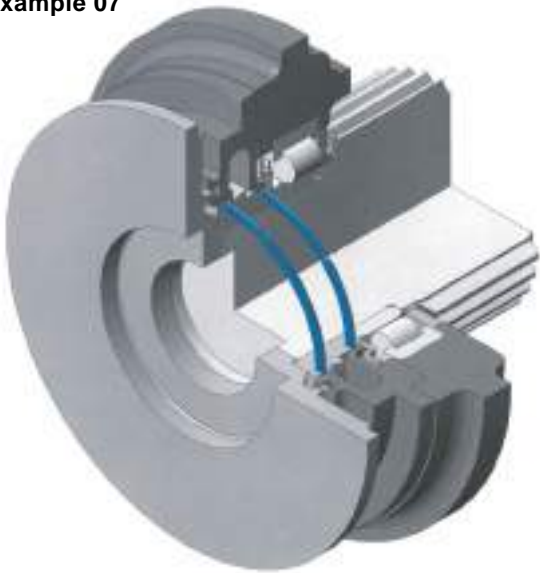

Example 08



Example 09

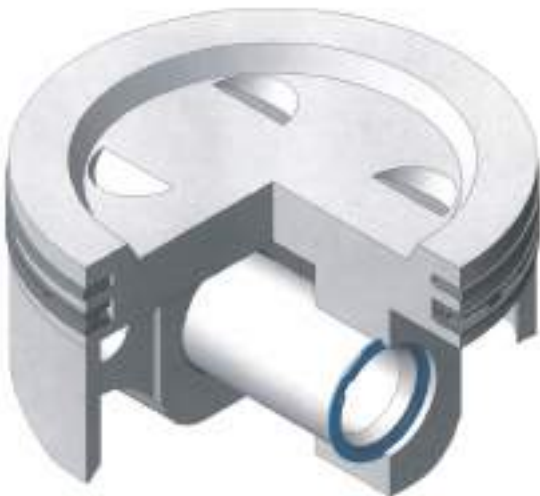

Example 10



Example 11



Example 12



**We support you worldwide with
22 agencies**



**Fey Lamellenringe Vertriebs GmbH
Einödstraße 18
A-2511 Pfaffstätten
Austria**

Tel:+43(0)2252/88640

Fax:+43(0)2252/886402

E-Mail: office@feylamellenringe.com

Homepage: www.feylamellenringe.com